

# CUTA 1875205A

REV	DATE	BY	DESCRIPTION
A	02-05-68	PS	INITIAL RELEASE
2	01-29-75	KMN	PART# WAS 18752
3	02-26-10	KD	DRAWN TO CAD ADDED MARKING.
4	03-08-10	KD	ADDED LEE TO MARKING

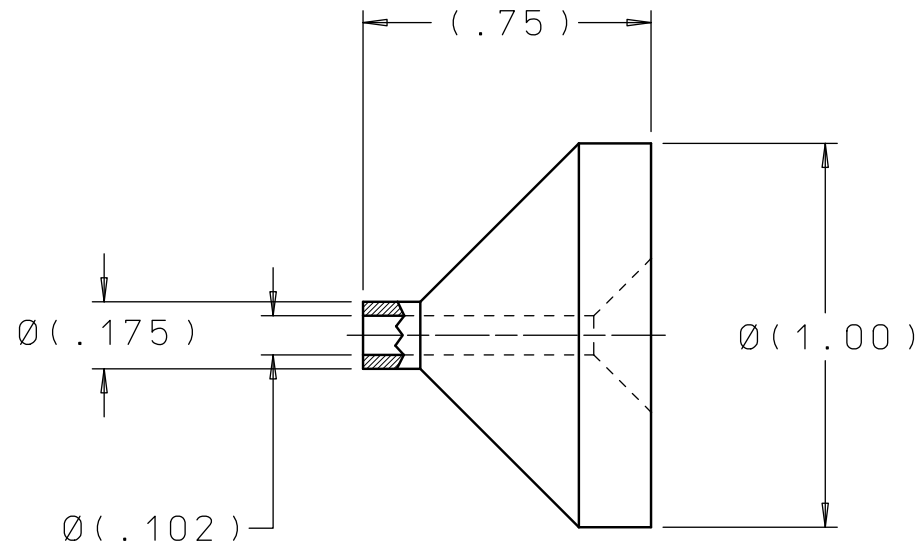

PUSHER  
CUTA 1875305A

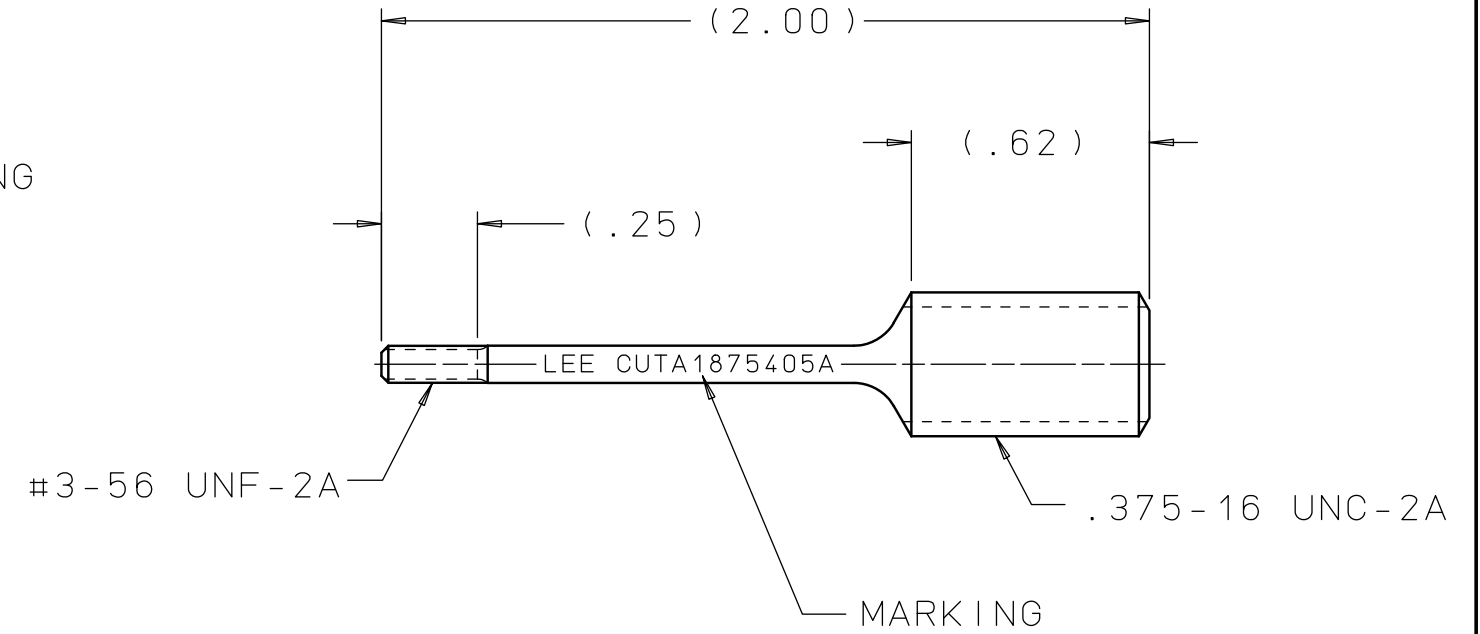
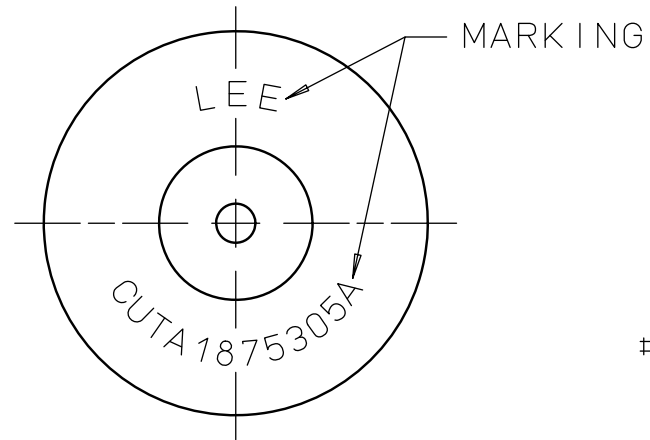

STUD  
CUTA 1875405A

### PROPRIETARY ITEM

This document contains proprietary information and is submitted upon the express condition that the information contained herein will not be used directly or indirectly in any way detrimental to the interests of The Lee Company, and/or in violation of regulation DAR 7-104.9(a)(1 July 1974), et seq.

CUTD1875205  
REFERENCE

DWG NO: CUTA 1875205A	NOTES AND DIMENSIONS SHOWN HERE ON ARE FOR INSPECTION IDENTIFICATION ONLY. ALL MANUFACTURING RIGHTS RESERVED.		DRAWN BY: P S 02-05-68	LEE RFO HYDRAULIC INSTALLATION TOOL SET	
	EXTERNAL CORNER RAD: INTERNAL FILLET RAD:		CHK'D BY: JFM 02-08-68	<b>THE LEE COMPANY</b> WESTBROOK, CT 06498	
	SURFACE FINISH ✓ ALL OVER DIMENSIONS ARE IN INCHES		APP'D BY: E L 02-09-68		
	TOLERANCES 2 PLACES ±.015 3 PLACES ±.005 ANGLES ±5°		MAT:	SIZE: B	CAGE CODE: 92555
			H.T.:	REV: A	DWG SCALE: NONE
			FINISH:	SHEET 1 OF 1	