

Installation Procedure IP SBP 11

REVISION HISTORY

Revision	Date	Change
A	6/19/2015	Initial Release
A1	4/22/2016	Updated Approvals List
B	5/16/2018	Revised 2.
C	8/27/2020	Updated pages 4 & 7
D	12/16/2022	Added Appendix E
E	2/17/2022	Updated Section 3 and 3.3

11 mm Short Betaplug[®]

FACTORY INSTALLATION PROCEDURE

Table of Contents

1. OVERVIEW 2

2. INSTALLATION HOLE REQUIREMENTS..... 2

3. INSTALLATION..... 3

3.1. *INSTALLATION EQUIPMENT*..... 4

3.2. *STANDARD FACTORY INSTALLATION* 5

3.3. *USING INSTALLATION FORCE VS. TOOL TRAVEL CURVE AS CONTROL* 6

4. APPENDICES 7

4.1. *APPENDIX A: DIAGRAM OF FACTORY INSTALLATION* 7

4.2. *APPENDIX B: INSTALLATION HOLE DIMENSIONS*..... 8

4.3. *APPENDIX C: INSTALLATION TOOL DIMENSIONS*..... 8

4.4. *APPENDIX D: FEED BOWL EJECT SLOT*..... 9

4.5. *APPENDIX E: PROMESS, INC. PRESS INFORMATION*..... 10

1. Overview

This procedure is intended to provide process guidelines for proper installation of 11 mm Short Betaplug®. Section 2 provides an overview of the installation hole requirements as typically recommended for the Betaplug. Section 3 contains the installation procedure. Section 4 contains a diagram of proper orientation and position of the product with respect to the installation hole and installation tool.

Compliance with this installation procedure will ensure optimal product performance. Please contact your local Lee Company Sales Representative for any additional questions concerning installation of Lee Company products.

2. Installation Hole Requirements

The 11 mm Short Betaplug® is purposely designed to perform well under adverse conditions. Therefore, the installation hole specifications outlined in this section should be followed precisely to ensure proper function of the Betaplug's expansion sealing features. Installation forces and pressure ratings are based on installations in aluminum housings or manifolds.

Installation hole specifications, as found on Lee Drawing 1INST002870S (Appendix B), will ensure proper performance of the 11 mm Short Betaplug. The Lee Company recommends that the Betaplug be installed below the surface of the housing to ensure optimum performance. The hole should be clean, dry and free of burrs. Surface finish should be between 0.8µm and 3.2µm (Ra) with no longitudinal surface defects. Surface finish requirements must be given special attention. Holes with a surface finish below Lee's minimum specification (0.8 µm) may allow the plug to travel too far down the installation hole and not install properly. Speeds, feeds and tool design must be established with the machining equipment to fabricate the installation holes so that these surface finish requirements are met. If needed, The Lee Company has tapered reamers available. Special serrated roughing reamers are also available which create a rougher surface finish in aluminum to fall within the Lee specification. The tapered reamer for the 11 mm Short Betaplug is part number PLBT1100012S and the serrated/roughing version is part number PLBT1100014S.

The Lee Company does not recommend the use of coatings or surface treatments in the area of the installation hole where the Betaplug is to be installed. These may reduce Betaplug retention and performance.

3. Installation

Installation Overview – All Betaplug pins are coated with a wax that provides a thin, solid lubricating film that reduces friction, allowing the pin to be driven to its correct position relative to the plug. Do not clean prior to installation.

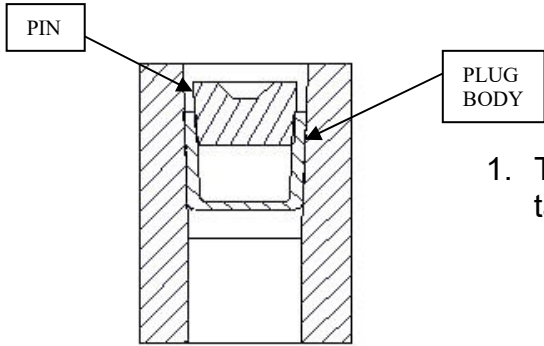

BETAPLUG IN
INSTALLATION HOLE

1. The 11 mm Short Betaplug[®] is inserted into the tapered installation hole narrow end first.

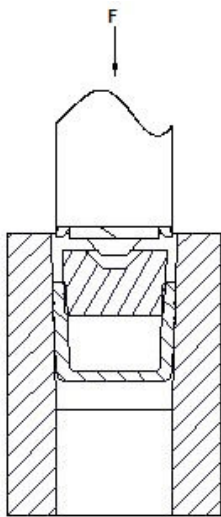

INSTALL/STAKE
PLUG ONTO PIN

2. The installation tool (PLBT0110901S) is inserted into the hole above the Betaplug. A non-impact load is applied by the tool which drives the pin into the plug body. Features on the end of the tool push the pin below flush of the plug body by the proper amount and stake four tabs over the back of the pin. The tool contains a centering feature which ensures proper alignment during installation.

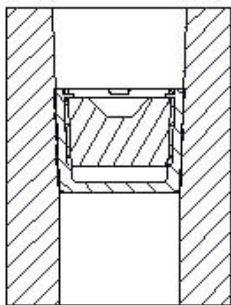

INSTALLATION
INSPECTION

3. When the installation tool is retracted the installed Betaplug can be inspected by measuring the depth of the pin relative to the plug body. This distance should be between 0.50 to 0.80 mm below flush. Staking tabs should be clearly visible (see photo Section 3.1 and diagram in Appendix A).



Photograph of a properly installed Betaplug which shows four staked tabs above the pin from the installation tool. The presence of these staked tabs and the pin being the correct distance below flush indicates a properly installed Betaplug.

Vision systems have been used to verify Betaplug installations in automated assembly applications by identifying the presence of these tabs.

3.1. Installation Equipment

The 11 mm Short Betaplug® has been extensively tested using pneumatic, hydraulic and electro press equipment to perform the installations. An electric servo-press system is recommended for high volume production as it provides detailed feedback for better in-process control of the installation process. The housing in which the Betaplug is to be installed should be held stationary on a solid surface. The Betaplug is expanded by the insertion of the pin by an installation tool under load. Adjust the press stroke to eliminate excess over-travel as this may damage installation holes if Betaplug is not present. Adjust the press supply pressure to limit the maximum load force to 7000 Newtons.

Installation should be done using Betaplug Installation/Staking Tool p/n PLBT0110901S (see Appendix C). The installation tool and the installation hole need to be concentric to each other within 0.25 mm, see diagram in Section 4. The housing or manifold containing the installation hole must be stationary and secure when installation force is applied. For further information about the recommended electric servo-press system from Promess, Inc. see Appendix E.

3.2. Standard Factory Installation

1. Firmly support the housing or manifold in which the Betaplug is to be installed.
2. Insert the Betaplug into installation hole, narrow end first, until the plug is seated on the mating taper of the installation hole.
3. Apply a non-impact installation force between 5500 and 7000 Newtons using Installation Tool part number PLBT0110901S. The tool can approach the Betaplug at a rate of 20-35 mm/sec. The maximum speed of the tool during installation should be limited to 3 mm/sec.
4. Installation Tool Travel versus Installation Force can be plotted to ensure proper installation. See the installation signature curve in Section 3.3.
5. Inspect the Betaplug for proper installation by measuring depth of pin relative to the top of the plug and verify the presence of 4 staked tabs. The pin should be below the top of the plug by 0.5 to 0.8mm (see diagram in Appendix A).
6. Retract tool and follow the procedure above for all additional installations.

Factory Best Practices:

1. Examine the condition of the installation tool at appropriate intervals and replace if damaged or chipped.
2. Clean feed bowls once per day.
3. Turn off vibratory feed bowl when the assembly station is idle, or if the feed rail is full of parts.
4. Use the minimum vibration setting necessary to advance plugs in the feed bowl.
5. Include an escapement or cutout in the feed bowl to eject separated Betaplug assemblies (pin and/or plug) preventing separated components from being fed into the assembly station. See photos in Appendix D.
6. If the Betaplug is blown into the assembly area from the feed rail, minimize the air pressure at which the Betaplug is blown into the assembly area to prevent possible damage.
7. Use rate of change detection technology from Promess, this method uses closed-loop feedback from the sensors included in the system to control the press to a Rate of Change. Please contact your local Lee Company sales representative or Promess for more information, see Appendix E.

3.3 Using the Install Force vs. Tool Travel Curve as Control

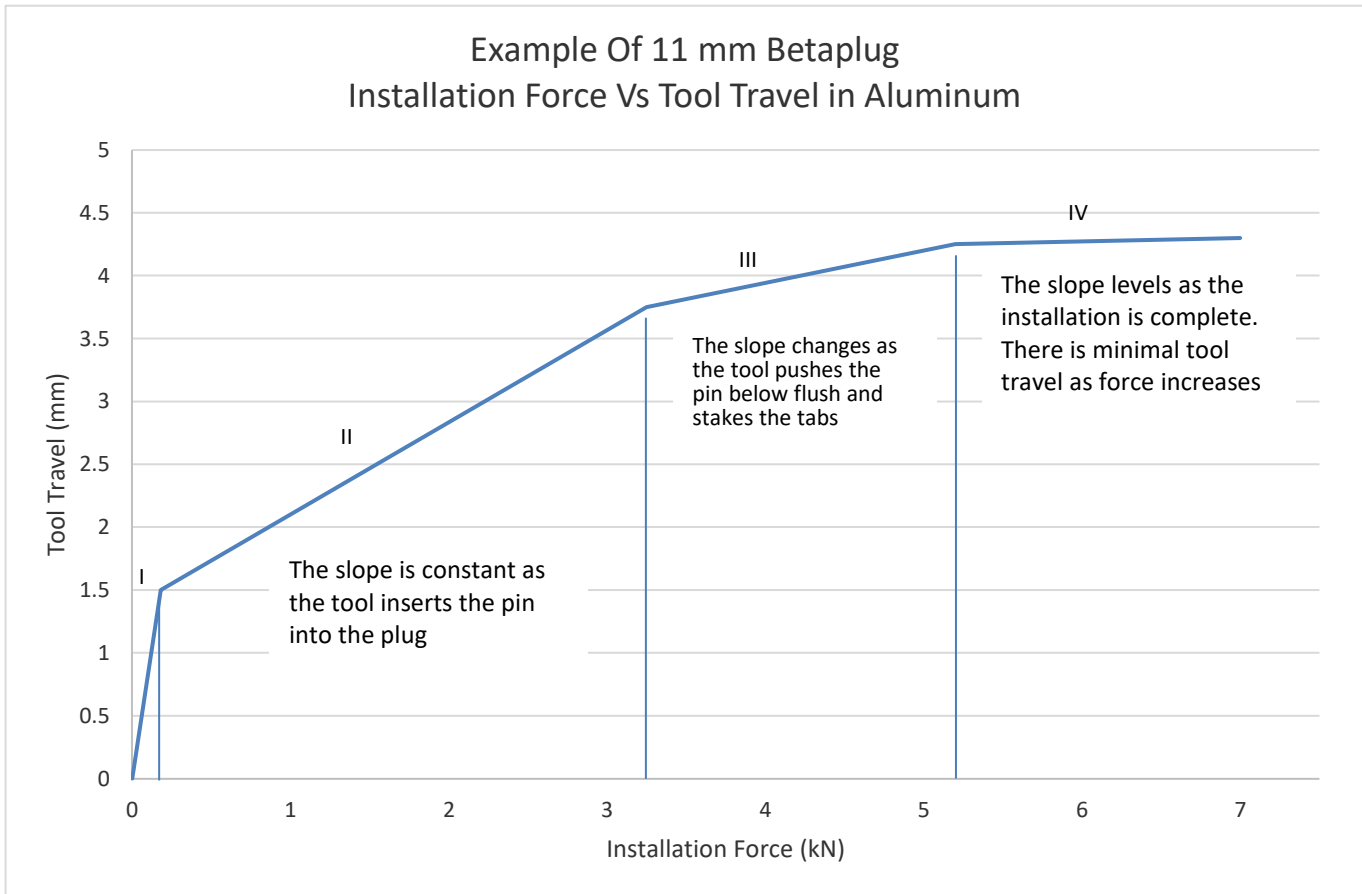

Using automated press equipment that monitors force and displacement has proven to be successful in ensuring consistent proper installation of the 11 mm Short Betaplug. The plot of Tool Travel vs. Install Force above illustrates the signature that defines the proper installation of a 11 mm Short Betaplug.

- I. The initial steep slope is consistent with the tool making first contact with the Betaplug pin. The tool pushes the Betaplug assembly down the hole until it is firmly seated on the mating taper of the installation hole.
- II. The slope of the curve becomes more gradual as the pin is inserted and the plug body expands outwardly sealing the hole.
- III. The next inflection point in the curve is indicative of the pin being pressed below flush of the plug as the staking nubs on the installation tool forms the staked tabs above the pin.
- IV. Lastly, the curve levels out when the installation is complete, and the tool exhibits minimal travel with increasing load. This point is recognized by the rate of change programming in the press control software and a signal is sent to stop the press preventing over pressing.

The speeds of the press need to be limited to prevent a significant overload of the plug after proper installation. Overloading the 11 mm Short Betaplug may result in forcing the assembly farther down the installation hole reducing performance. We recommend approaching the 11 mm Short Betaplug with a tool speed of 20 – 35 mm/sec and reducing the tool speed to a maximum of 3 mm/sec during pin installation.

4. Appendices:

4.1 Appendix A: Diagram of Factory Installation

(Section View of Hole, 11 mm Short Betaplug®, and Installation Tool)

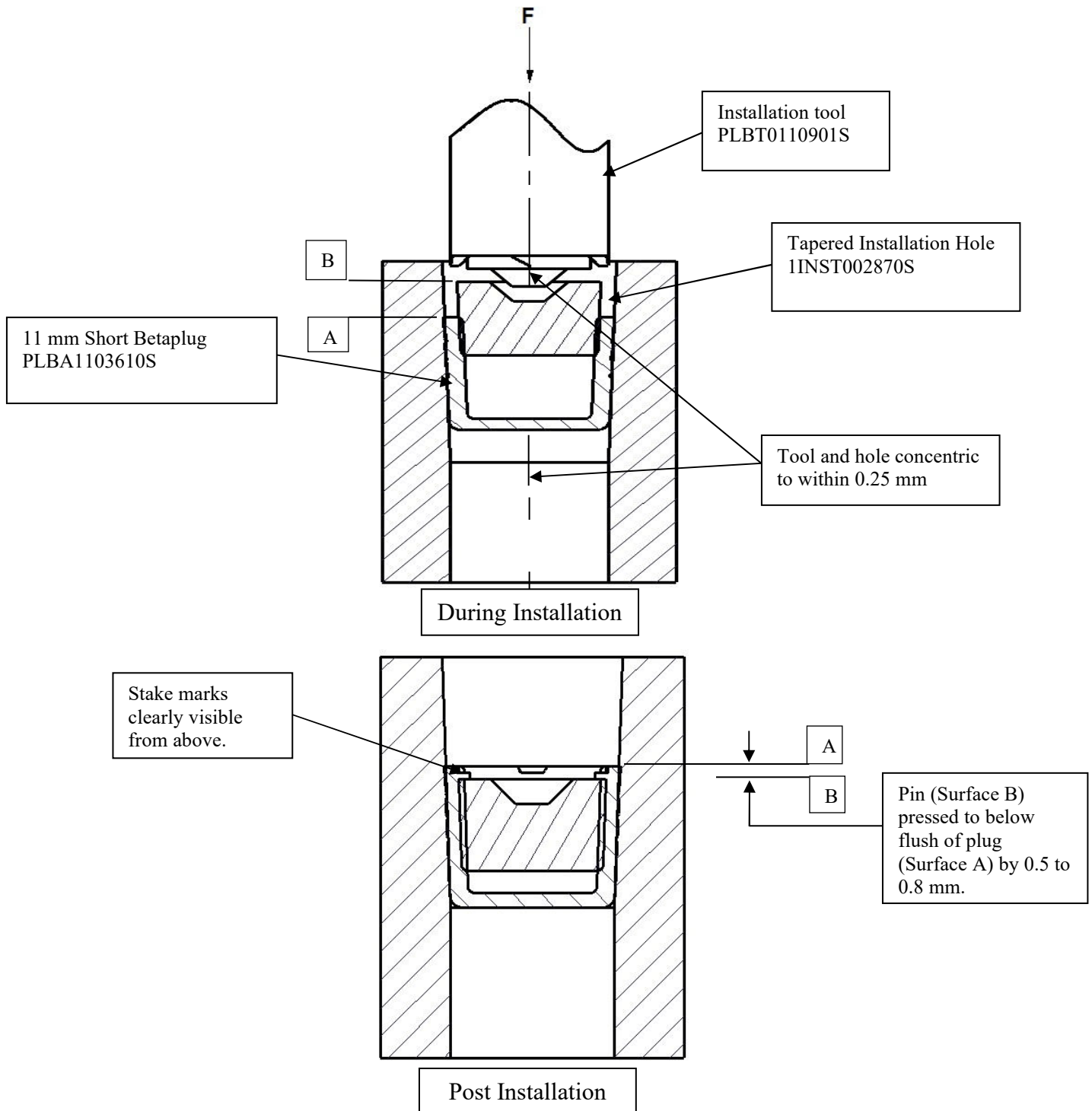

4.2 Appendix B: Installation Hole Dimensions

Dimensions in millimeters

Refer to Lee Drawing No. 1INST002870S

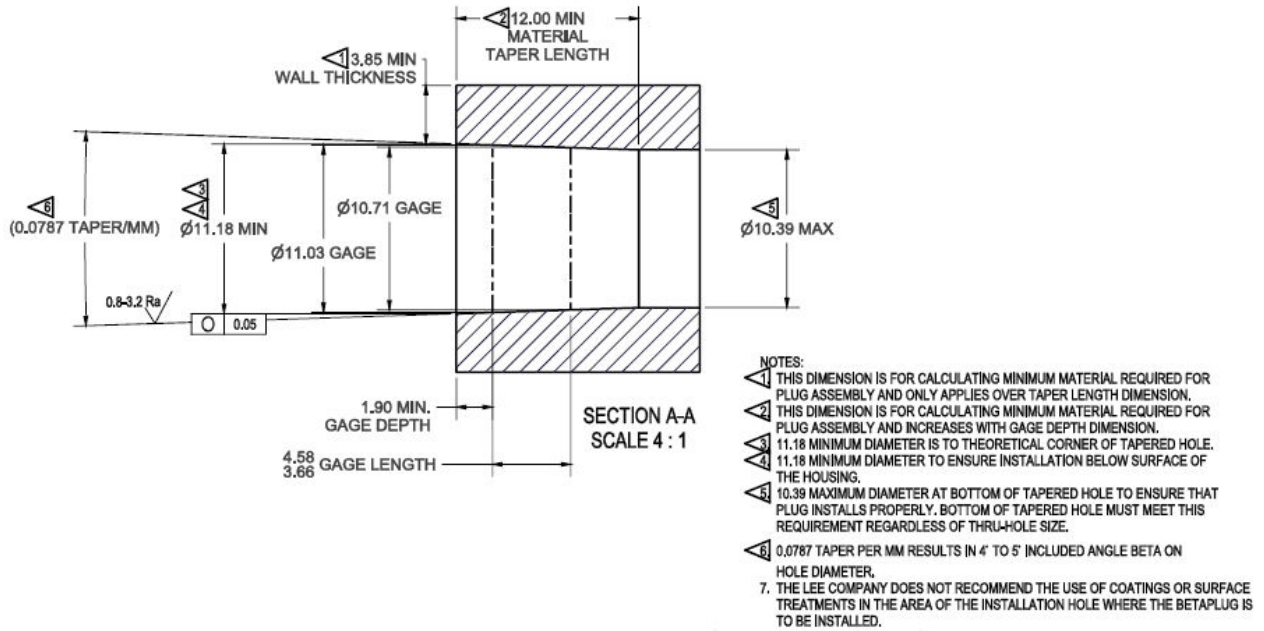

4.3 Appendix C: Installation Tool Dimensions

Dimensions in inches

Refer to Lee Drawing No. PLBT0110901S

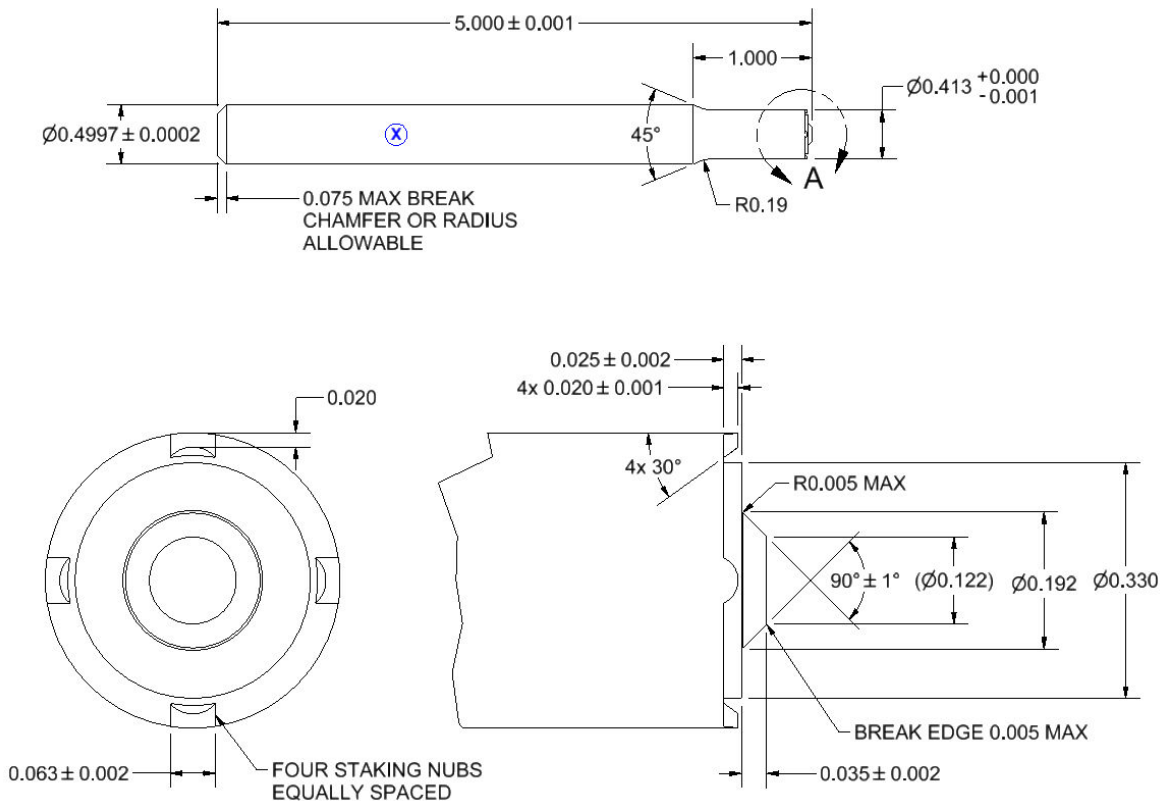

4.4 Appendix D: Feed Bowl Eject Slot

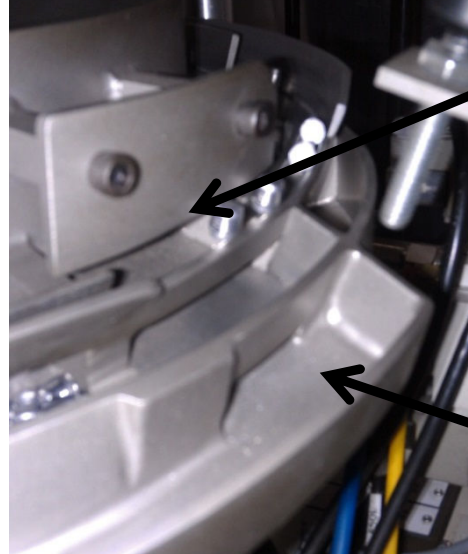
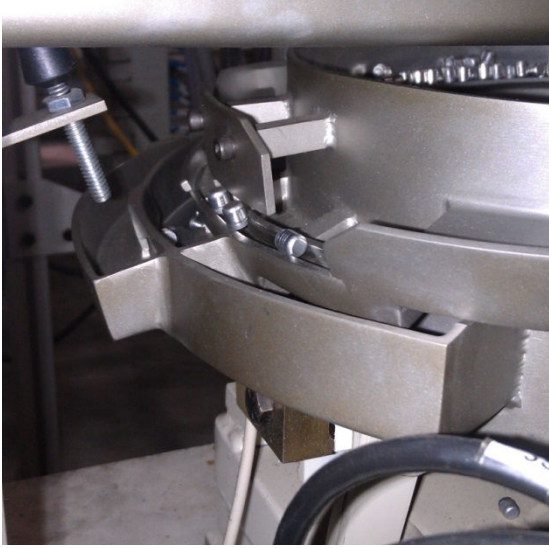

Separated pins and plugs fall off bowl track through use of a sorting plate and travel out of feed bowl.

Separated pins and plugs fall into this area



4.5 Appendix E: Promess, Inc. Press Information

Contact:

Promess, Inc.
11429 Grand River Road
Brighton, MI 48116
Phone: (810) 229-9334
Web: www.promessinc.com

Press Information:

Low Volume: EMAP 8kN/200mm – FEMP8/200MP

High Volume: EMAP 12kN/200mm – FEMP12/200MP

Includes the following:

- Press w/ integrated load cell, motor mounting plate and Motor
- PreAmplifier (Connected to the Press Load Cell and Prox Switch)
- MotionPRO Servo Amplifier
- Motor Power Cable
- Motor Encoder Cable
- PreAmplifier Cable
- MotionPRO software

