

Installation Procedure IP 6.5 mm Press-In R

REVISION HISTORY

Revision	Date	Change
A	10/18/2016	Initial Release
B	4/28/2017	Correct Appendix B
C	6/27/2017	Add units to appendices
D	6/29/2017	Updated 4.0
E	7/15/2022	Formatting and naming

*Installation Procedure, Lee Check Valve,
 6.5 mm, Press-In for Reverse Flow*

FACTORY INSTALLATION PROCEDURE

Table of Contents

1. OVERVIEW 2

2. INSTALLATION HOLE REQUIREMENTS..... 2

3. INSTALLATION 3

INSTALLATION OVERVIEW..... 3

FACTORY BEST PRACTICES..... 4

4. APPENDICES 5

APPENDIX A: INSTALLATION HOLE DIMENSIONS.....5

APPENDIX B: INSTALLATION TOOL DIMENSIONS 5

1. Overview

This procedure is intended to provide process guidelines for proper installation of Lee Check Valve, 6.5 mm, Press-In product in reverse flow orientation. Section 2 provides an overview of the installation hole requirements. Section 3 contains the installation procedure and customer assembly process recommendations. Section 4 contains reference information on the installation hole and installation tool.

Compliance with this installation procedure will ensure optimal product performance. Please contact your local Lee Company Sales Representative for questions concerning installation of Lee Company products.

2. Installation Hole Requirements

The Lee Check Valve, 6.5 mm, Press-In product is purposely designed for installation into plastic manifolds or fittings and to perform well under adverse conditions. Therefore, the installation hole specifications outlined in this section should be followed precisely to ensure proper function of the product's retention and sealing features.

Installation hole specifications as found on Lee Installation Hole Drawing 1INST085542S (Appendix A) will ensure proper operation of the Lee Check Valve, 6.5 mm, Press-In product. The hole should be clean, dry, and free of burrs/flash. The series of smoothly curved lands of the Lee Check Valve, 6.5 mm, Press-In product allow the valve to be pressed in while the plastic flows into the adjacent grooves. Some plastics with a lot of elongation, such as Polypropylene, Nylon, Acetal, Polyethylene and PEEK, cold flow into the grooves affecting retention and sealing.

Other plastics, such as acrylic and polycarbonate, are rigid and therefore the material must be heat flowed around the component. For installation into these types of plastics contact your local Lee Company Sales Representative for more information.

3. Installation

Installation Overview For Reverse Flow Installation

1. For reverse flow applications the Lee Check Valve, 6.5 mm, Press-In product is inserted into the installation hole oriented as shown.

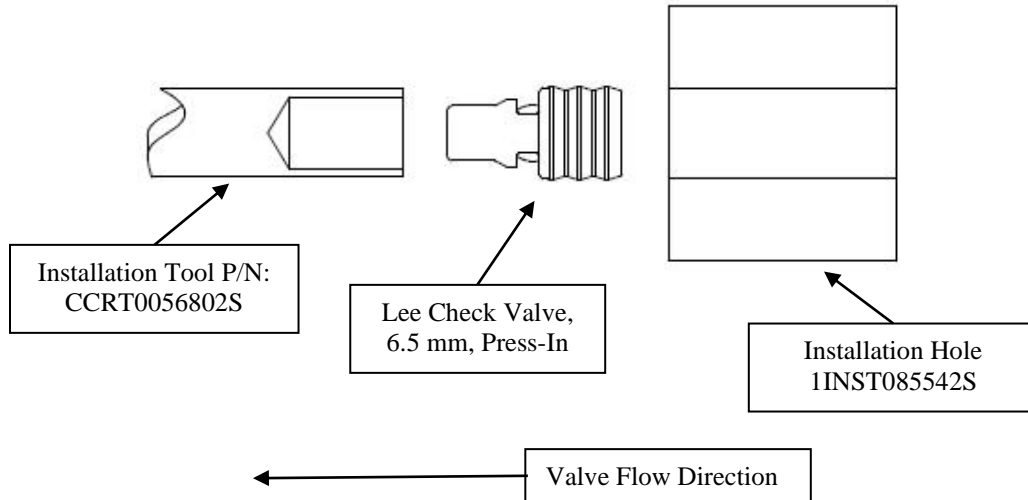

2. The installation tool (P/N: CCRT0056802S) is used to simply press the valve into a plastic installation hole until the valve is at a minimum flush with the top of the installation hole.

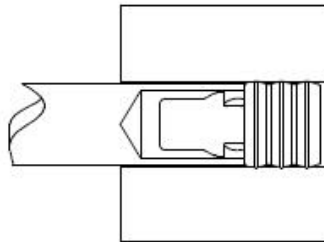

3. The series of smoothly curved lands of the Lee Check Valve, 6.5 mm, Press-In product seals and retains the product in the plastic installation hole.
4. Insertion should be done using Lee Installation Tool P/N: CCRT0056802S (see Appendix B). The tool and installation hole should be concentric within 0.03 mm.

Factory Best Practices:

1. Examine the condition of the Installation Tool at appropriate intervals and replace if damaged or chipped.
2. Clean feed bowls once per day.
3. Turn off vibratory feed bowl when the assembly station is idle, or if the feed rail is full of parts.
4. Use the minimum vibration setting to advance valves in the feed bowl.
5. If the check valve is blown into the assembly area from the feed rail, minimize the air pressure at which the check valve is blown into the assembly area to prevent possible damage.

4. Appendices

Appendix A Installation Hole

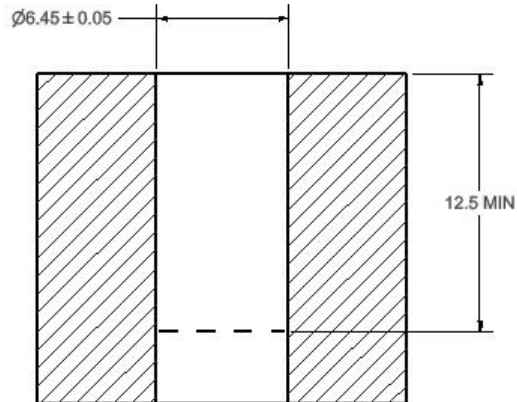

DIMENSIONS IN MILLIMETERS

Note: Draft angle to fall within diameter tolerance.

Refer to Lee Drawing No. 1INST085542S for complete specifications.

Appendix B Installation Tool

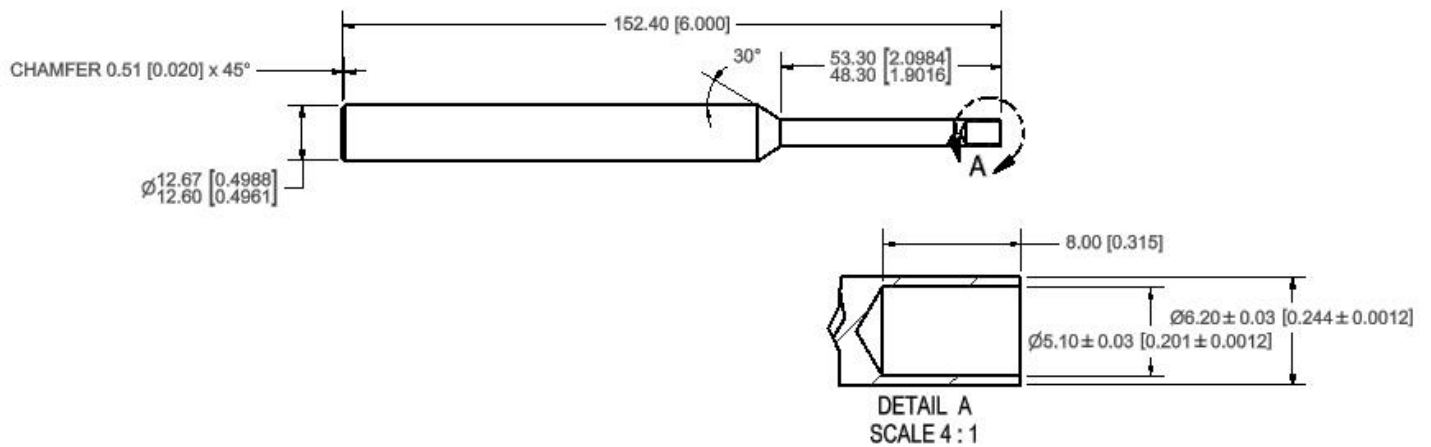

DIMENSIONS IN MILLIMETERS

 Marked with part number and revision.

Refer to Lee Part No. CCRT0056802S for complete specifications.