

CUTA3750363A

REV	DATE	BY	DESCRIPTION
A	03-05-20	KD	INITIAL RELEASE

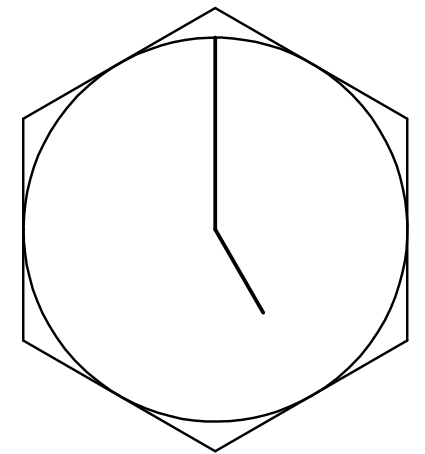
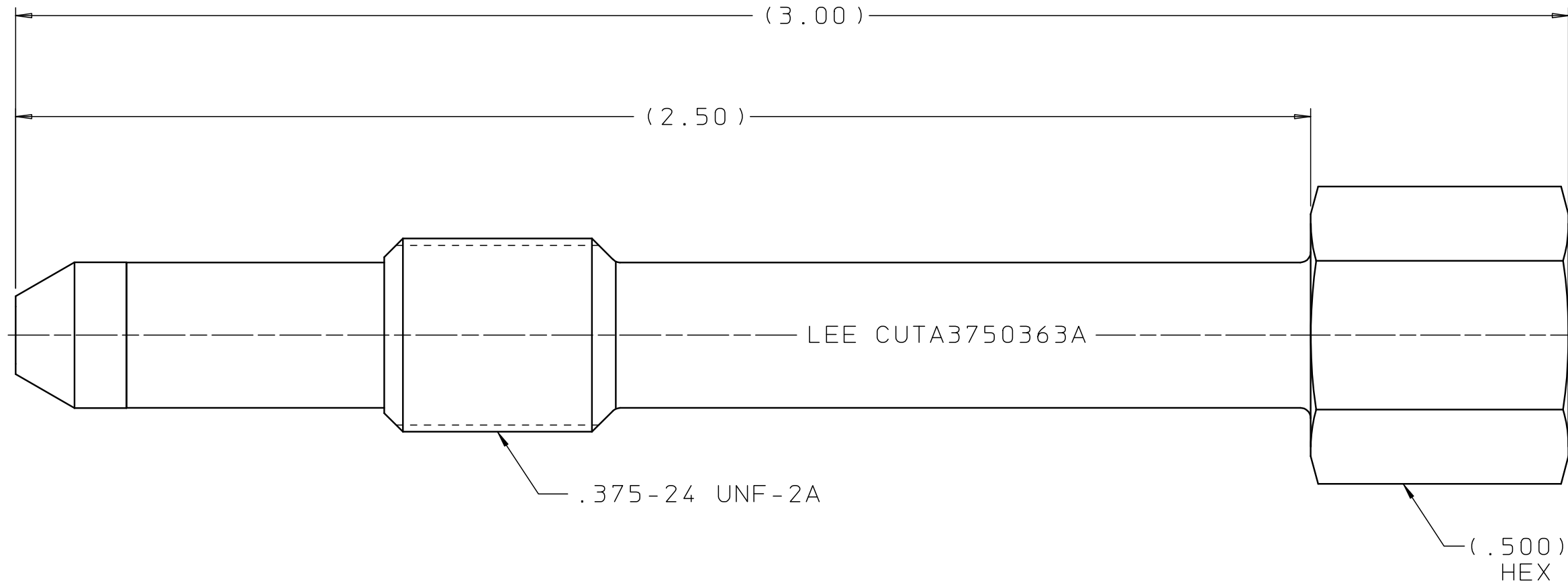

ROTATION MARKING VIEW

NOTES:
1. FOR USE WITH PLAA3724220A.

PROPRIETARY ITEM

This document contains confidential, trade secret information which is proprietary to The Lee Company, and is submitted upon the express condition that neither it, nor our products, will be used directly or indirectly in any way detrimental to the interests of The Lee Company, such as disclosure to others or replication of our products, and/or in violation of 18 U.S.C. 1905 (TSA), 5 U.S.C. 552 (FOIA), E.O.12600 of 6/23/87, 18 U.S.C. 1832, and C.G.S.A. (CT) Chapter 625 sec. 35-50 thru 35-58.

CUTD3750363
REFERENCE

DWG NO: CUTA3750363A	NOTES AND DIMENSIONS SHOWN HERE ON ARE FOR INSPECTION IDENTIFICATION ONLY. ALL MANUFACTURING RIGHTS RESERVED.		DRAWN BY: K D	03-05-20	LEE TOOL, COINING	
	EXTERNAL CORNER RAD: INTERNAL FILLET RAD:		CHK'D BY: D R	03-09-20	.375-24 STANDARD DSAFO	
	SURFACE FINISH ✓ ALL OVER DIMENSIONS ARE IN INCHES		APPD BY: R M	03-12-20	 THE LEE COMPANY WESTBROOK, CT 06498	
	TOLERANCES 2 PLACES 3 PLACES ANGLES ±.015 ±.005 ±5°		MAT:	H.T.:		
		FINISH:	SIZE: B	CAGE CODE: 92555	DWG NO.: CUTA3750363A	REV: A
		DWG SCALE: NONE		SHEET 1 OF 1		