



ENG. DOC. NO. **INIX0500400A** REV. **A4**

REV	DATE	BY	DESCRIPTION
A4	01/28/2021	JAV	UPDATED TO REFLECT WASHER & FERRULE AS A SUB-ASSEMBLY. STEP 5 WAS STEP 6. REMOVED ORIGINAL STEP 5.

D

D

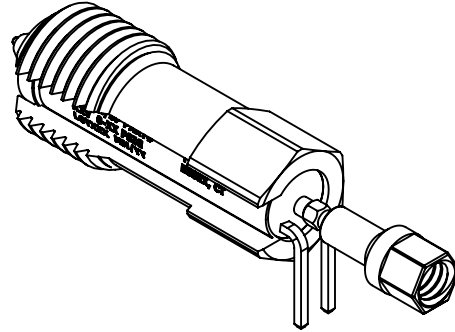

C

C

B

B

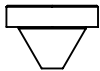
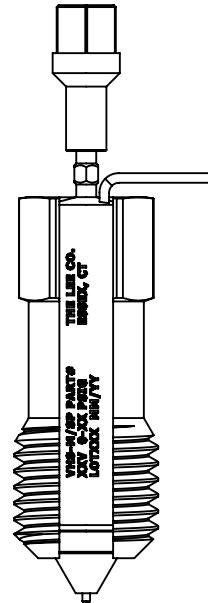
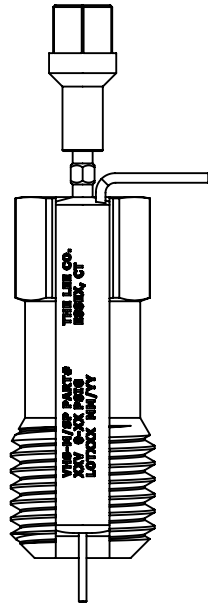
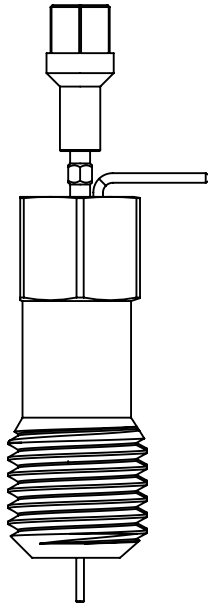
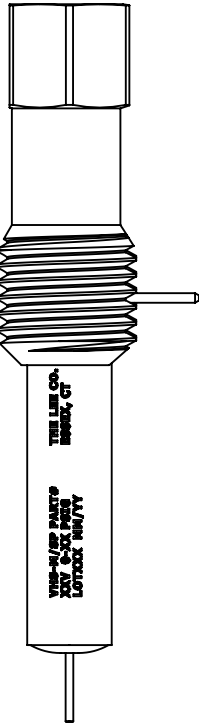
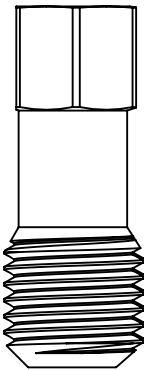

STEP 1

STEP 2

STEP 3

STEP 4

STEP 5

NOTES:

- TORQUE TO: APPROXIMATELY 24 ozf in (170 mN-m) DEPENDING ON THE BOSS MATERIAL AND FINISH.

A

A

-FMF-  
THE LEE CO  
ESSEX, CT

DRAWN BY	BFF	02/28/2017
CHECKED BY	MLC	01/29/2021
APPROVED BY	DJS	06/17/2021

TITLE  
**SLEEVE VHS-ASSY SEQUENCE**



**The Lee Company**  
55 Bokum Rd., Essex, CT 06426  
www.theleeco.com

**PROPRIETARY NOTICE**  
This document contains confidential, trade secret information which is proprietary to The Lee Company, and is submitted upon the express condition that neither it, nor our products, will be used directly or indirectly in any way detrimental to the interests of The Lee Company, such as disclosure to others or replication of our products, and/or in violation of 18 U.S.C. 1905 (TSA), 5 U.S.C. 552 (FOIA), E.O. 12600 of 6/23/87, 18 U.S.C. 1832, and C.G.S.A. (CT) Chapter 625 sec. 35-50 thru 35-58.

NOTES AND DIMENSIONS SHOWN HEREIN ARE FOR INSPECTION IDENTIFICATION ONLY. ALL MANUFACTURING RIGHTS ARE RESERVED.

**WARNING**  
EXPORT CONTROLLED BY  
EAR [50 USC 2401]  
ECCN=EAR99

ENG DOC NO.  
**INIX0500400A**

REV.  
**A4**

CODE IDENT NO. ONZR4

SHEET 1 OF 1