

LEE IMH Chek™ Valve - 855 LC2 Series Insert

The Lee Company's new 855 LC2 Series Insert Chek Valve is a miniature, thread-less, cartridge-style check valve specifically designed for installation into metal manifolds. This new valve offers more than a 65% increase in flow capacity over the existing 855 series check valve. Designed for reliable operation, the new valve features robust, stainless steel construction. A high-quality metal to metal seat provides low leakage and highly repeatable cracking pressures. This robust design and 100% functional testing ensures consistent long-term performance.

Simple to install, the new check valve uses Lee's field-proven insert principle that provides secure retention and eliminates the need for threads, o-rings or in-house designs. To install, simply insert the check valve into a drilled installation hole and drive the expansion pin flush to seal and lock the valve in place.

The new 855 LC2 Chek Valve's compact size, superior performance, and ease of installation make it ideal for high volume applications in automotive, off-road, and other industrial hydraulic systems.

- Metal to metal seating
 - Provides high reliability
 - Long life
- 100% tested
 - Eliminates rework
- Leak tight
 - Efficient system performance
- Positive ball stop
 - Infinite spring life
 - Stable performance
- Integral locking end
 - Long life
 - No o-rings to fail



ACTUAL SIZE

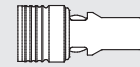

(As Installed)

CHEK VALVE

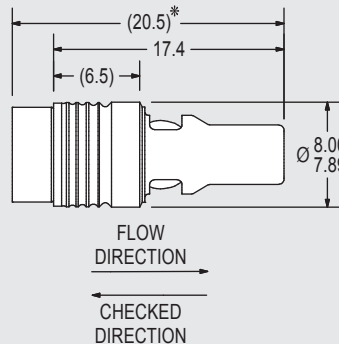

INSTALLATION HOLE

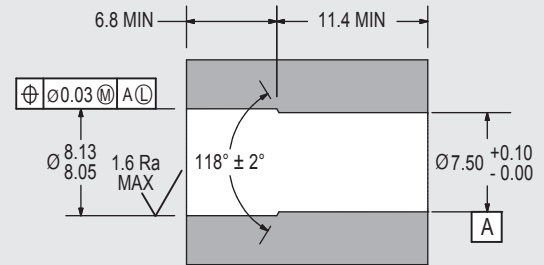

*LOA before installation.

All dimensions in millimeters, except where noted.

ΔP vs. Flow on Water @80°F (27°C)

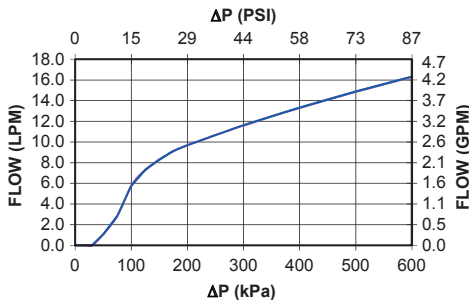

Flow Curve for 40 kPa Valve

PERFORMANCE

- Lohm Rate: 45 Lohms*
- Leakage: 20 sccm/min. (max.) @ 172 kPa (25 psid) on air
1 Drop/min. (max.) on hydraulic fluid
- Maximum Working Pressure:
28 MPa (4,060 psid) (Checked Direction)
4 MPa (580 psid) (Flow Direction)
- Materials: Body, Cage, Ball, Pin and Spring are Stainless Steel.

*Lohm is a measure of flow resistance. See back page for more information.

LEE PART NUMBER	CRACKING PRESSURE
CLCF8010000S	0 kPa (No Spring)
CLCF8010004S	4 kPa ± 3 kPa (0.6 ± 0.4 psid)
CLCF8010007S	7 kPa ± 5 kPa (1 ± 0.7 psid)
CLCF8010014S	14 kPa ± 5 kPa (2 ± 0.7 psid)
CLCF8010040S	40 kPa ± 15 kPa (6 ± 2.2 psid)
CLCF8010069S	69 kPa ± 17.3 kPa (10 ± 2.5 psid)

LEE PART NUMBER	CRACKING PRESSURE
CLCF8010100S	100 kPa ± 15 kPa (14.5 ± 2.2 psid)
CLCF8010200S	200 kPa ± 30 kPa (29 ± 4.4 psid)
CLCF8010300S	300 kPa ± 45 kPa (43.5 ± 6.6 psid)
CLCF8010400S	400 kPa ± 60 kPa (58 ± 8.8 psid)
CLCF8010500S	500 kPa ± 75 kPa (72.5 ± 10.9 psid)

LEE IMH Chek™ Valve - 855 LC2 Series Insert

SIMPLE TO INSTALL

Insert the valve into a drilled installation hole. Drive the expander pin flush to within 0.25mm (0.010") above flush of the check valve body. Use a maximum installation force of 680 KgF (1,500 lbs. force).

The installation tool can bottom on the insert body with no consequence. Lee Installation Tool part number CCRT0900150S is available.

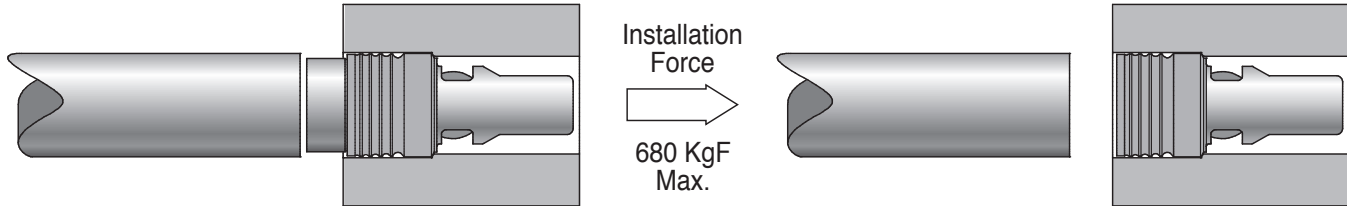

LOHM LAWS

LOHMS LAWS (liquids)

Every engineer will be interested in our simple system of defining the fluid resistance of Lee hydraulic components.

Just as the OHM is used in the electrical industry, we find that we can use a liquid OHM or "Lohm" to good advantage on all hydraulic computations.

When using the Lohm system, you can forget about coefficients of discharge and dimensional tolerances on drilled holes. These factors are automatically compensated for in the Lohm calculations, and confirmed by testing each component to establish flow tolerances. The resistance to flow of any fluid control component can be expressed in Lohms.

The Lohm has been selected so that a 1 Lohm restriction will permit a flow of 100 gallons per minute of water with a pressure drop of 25 psi at a temperature of 80° F.

LIQUID FLOW FORMULA

The following formulas are presented to extend the use of the Lohm laws to many different liquids, operating over a wide range of pressure conditions.

These formulas introduce compensation factors for liquid density and viscosity. They are applicable to any liquid of known properties, with minimum restrictions on pressure levels or temperature.

The units constant (K) eliminates the need to convert pressure and flow parameters to special units.

$$\text{Volumetric Flow Units } L = \frac{KV}{I} \sqrt{\frac{H}{S}} \quad \text{Gravimetric Flow Units } L = \frac{KV}{w} \sqrt{HS}$$

NOMENCLATURE

- L = Lohms
- S = Specific gravity*
- H = Differential pressure
- V = Viscosity compensation factor**
- I = Liquid flow rate: Volumetric
- w = Liquid flow rate: Gravimetric
- K = Units Constant – Liquid (see chart below)
- *S = 1.0 for water at 80°F.
- **V = 1.0 for water at 80°F.

(For other fluids and temperatures, contact your Lee Sales Engineer or visit us at www.leeimh.com)

LIQUID FLOW - UNITS CONSTANT K

VOLUMETRIC FLOW UNITS			
Flow Units	Pressure Units		
	psi	bar	kPa
GPM	20	76.2	7.62
L/min	75.7	288	28.8
ml/min	75 700	288 000	28 800
in ³ /min	4620	17 600	1 760

GRAVIMETRIC FLOW UNITS			
Flow Units	Pressure Units		
	psi	bar	kPa
PPH	10 000	38 100	3 810
gm/min	75 700	288 000	28 800