

## LEE IMH 400 Bar Shuttle Valve

The Lee Company's Industrial Micro-Hydraulics Group (IMH) introduces the newest addition to our 400 Bar insert product line. The new Lee IMH 400 Bar Shuttle Valve is a miniature, economical and reliable solution to the problem of hydraulic isolation in manifolds. This new valve features a compact, non-detented, selective design that is just 6mm in diameter and 9.7mm long, and is ideal as a signal for auxiliary functions, such as hydraulically released, spring applied brakes as well as load sensing applications.

The Lee IMH 400 Bar Shuttle Valve is the smallest valve in its class as compared to other shuttle valves with similar flow rates. The all metal construction provides high reliability, yet leakage is drip tight. Each valve is 100% factory tested for flow and leakage to ensure consistent, long term performance.

This new cartridge-style shuttle valve installs easily into a drilled hole, eliminating the need for threads, o-rings or in-house designs. To install, simply insert the shuttle valve into a drilled hole and drive the expansion pin into the valve body to seal and lock the valve in place.

- Smallest in its flow class
  - Minimize housing size
- Leak tight
  - No system drift
  - No system losses
- Low shuttling pressure
  - Fast system response
- All metal retention and sealing
  - No threads necessary
  - No o-rings to fail

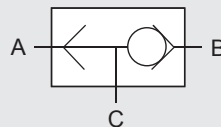

### SHUTTLE VALVE

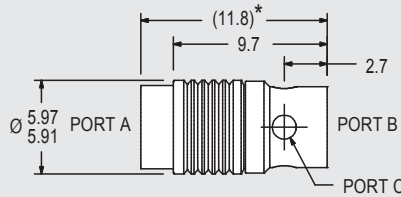

Flow Direction:  
Port A to Port C or Port B to Port C  
\* LOA before installation.

### ACTUAL SIZE



(As Installed)

### INSTALLATION HOLE

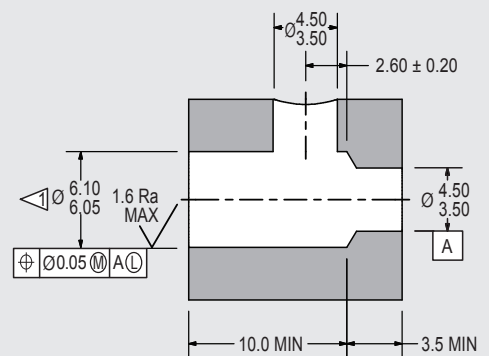

Finish machine this hole last.

All dimensions in millimeters, except where noted.

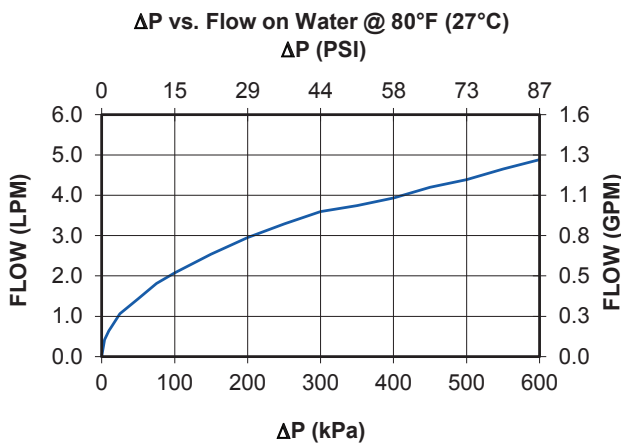

### LEE PART NUMBER

CCSV6010000S

### PERFORMANCE

Flow Rate: (A to C or B to C) – 150 Lohms\*  
3.9 LPM at 3.5 Bar (1.05 GPM at 51 psid) on hydraulic fluid

Shuttling Pressure: 7 kPa (1 psi) maximum

Leakage: A to B or B to A, 1 Drop/minute maximum after a 2 minute wait on hydraulic fluid at 6.9 MPa – 27.6 MPa (1,000 – 4,000 psid)

Maximum Working Pressure: 400 Bar (5,800 psid)

Materials: Stainless Steel

\* Lohm is a measure of flow resistance. See back page for more information.

## LEE IMH 400 Bar Shuttle Valve

### SIMPLE TO INSTALL

Insert the IMH Shuttle Valve into a drilled installation hole. The Lee Company does not recommend the use of coatings or surface treatments in the area of the installation hole where the Lee component is to be installed. Do not clean the insert prior to installation. The assembly is prelubricated for proper installation.

Seal and lock in place by driving in the expander pin with a minimum of 685 KgF (1,500 lbs. force) and a maximum of 908 KgF

(2,000 lbs. force). The ends of the expansion pin and insert will be flush to within  $\pm 0.25\text{mm}$  ( $\pm 0.010''$ ) above flush of each other. The installation tool can bottom on the insert body. The locking end seals Port A from Port C and retains the valve. During installation, the edge seal at the opposite end is driven into the housing, sealing Port B from Port C. Lee Installation Tool Part Number CCRT0051078S is available.

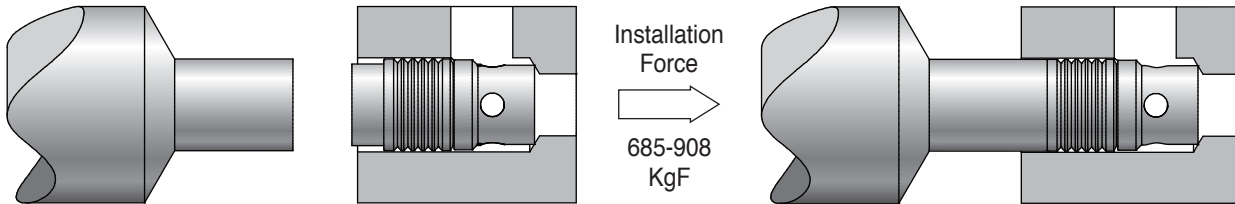

## LOHM LAWS

### LOHMS LAWS (liquids)

Every engineer will be interested in our simple system of defining the fluid resistance of Lee hydraulic components.

Just as the OHM is used in the electrical industry, we find that we can use a liquid OHM or "Lohm" to good advantage on all hydraulic computations.

When using the Lohm system, you can forget about coefficients of discharge and dimensional tolerances on drilled holes. These factors are automatically compensated for in the Lohm calculations, and confirmed by testing each component to establish flow tolerances. The resistance to flow of any fluid control component can be expressed in Lohms.

The Lohm has been selected so that a 1 Lohm restriction will permit a flow of 100 gallons per minute of water with a pressure drop of 25 psi at a temperature of 80° F.

### LIQUID FLOW FORMULA

The following formulas are presented to extend the use of the Lohm laws to many different liquids, operating over a wide range of pressure conditions.

These formulas introduce compensation factors for liquid density and viscosity. They are applicable to any liquid of known properties, with minimum restrictions on pressure levels or temperature.

The units constant (K) eliminates the need to convert pressure and flow parameters to special units.

$$\text{Volumetric Flow Units } L = \frac{KV}{I} \sqrt{\frac{H}{S}} \quad \text{Gravimetric Flow Units } L = \frac{KV}{w} \sqrt{HS}$$

### NOMENCLATURE

- L = Lohms
- S = Specific gravity\*
- H = Differential pressure
- V = Viscosity compensation factor\*\*
- I = Liquid flow rate: Volumetric
- w = Liquid flow rate: Gravimetric
- K = Units Constant – Liquid (see chart below)
- \*S = 1.0 for water at 80°F.
- \*\*V = 1.0 for water at 80°F.

(For other fluids and temperatures, contact your Lee Sales Engineer or visit us at [www.leeimh.com](http://www.leeimh.com))

### LIQUID FLOW - UNITS CONSTANT K

VOLUMETRIC FLOW UNITS			
Flow Units	Pressure Units		
	psi	bar	kPa
GPM	20	76.2	7.62
L/min	75.7	288	28.8
ml/min	75 700	288 000	28 800
in <sup>3</sup> /min	4620	17 600	1 760

GRAVIMETRIC FLOW UNITS			
Flow Units	Pressure Units		
	psi	bar	kPa
PPH	10 000	38 100	3 810
gm/min	75 700	288 000	28 800