



AN007: MICROFLUIDICS DRIVER – DISC PUMP APPLICATION NOTE

1.	INTRODUCTION	1
1.1.	About this Application Guide	2
2.	DISCLAIMER	2
3.	HEALTH AND SAFETY.....	2
4.	MICROFLUIDIC DRIVE SYSTEM.....	4
4.1.	Performance.....	4
4.2.	What limits performance?	4
4.3.	System components.....	5
4.4.	Ordering parts	6
4.5.	System schematic	6
4.6.	System operation	6
5.	SUPPORT	8
5.1.	Code snippet library	8
5.2.	Additional support	8
6.	REVISION HISTORY	8

1. INTRODUCTION

The Lee Company has worked with Sensirion to combine the SLF3x liquid flow sensor series with their piezoelectric disc pumps to create a development microfluidics driver. This application note details how exceptional liquid flow control can be achieved by combining our technologies. This approach suits a wide range of microfluidics applications, from IVD diagnostic instrumentation (including miniaturised systems for Point of Care) to droplet microfluidics.

The key features of the system:

- High-precision, stable flow-rate control.
- Large dynamic flow range (four orders of magnitude).
- Smooth liquid flow – no pulsation or oscillation.
- Rapid response to setpoint changes.
- Highly compact implementation possible.
- Pressure-driven flow approach supports reusable/disposable model where cross-contamination needs to be avoided.

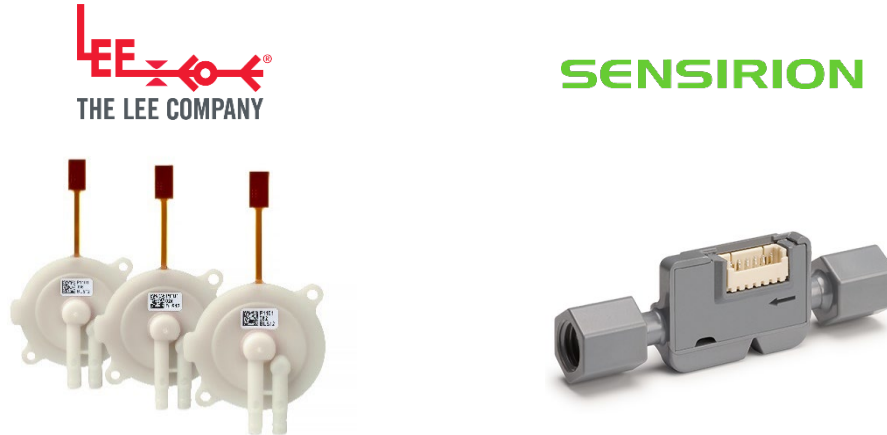

Figure 1. The Lee Company's Disc Pumps and Sensirion SLF3x series liquid flow sensor

1.1. About this Application Guide

This application guide explains the how to set up the same system for your own experiments.

In particular, it outlines:

- The performance that can be achieved with the system
- System components set up and operation
- Ordering information
- Resources to support the next stage of product development and integration

2. DISCLAIMER

This resource is provided "as is" and without any warranty of any kind, and its use is at your own risk. The Lee Company does not warrant the performance or results that you may obtain by using this resource. The Lee Company makes no warranties regarding this resource, express or implied, including as to non-infringement, merchantability, or fitness for any particular purpose. To the maximum extent permitted by law The Lee Company disclaims liability for any loss or damage resulting from use of this resource, whether arising under contract, tort (including negligence), strict liability, or otherwise, and whether direct, consequential, indirect, or otherwise, even if The Lee Company has been advised of the possibility of such damages, or for any claim from any third party.

3. HEALTH AND SAFETY

WARNING



The Piezoelectric Disc Pump General Drive PCB is capable of producing DC voltages up to 60V, and output AC voltages up to 120V peak- to- peak, at frequencies between 19 and 23 kHz. It is the user's responsibility to ensure that the Piezoelectric Disc Pump Driver PCB is used and/or integrated within any product in a safe manner. Read the user manual prior to first operation and take note of all safety notices.

WARNING



Take care during use of the Piezoelectric Disc Pump General Drive PCB not to create short circuits between exposed conductive parts of the board. Short circuits may lead to malfunctioning and heating.

WARNING



The liquid flow sensor is susceptible to ESD damage, especially when touching the connector pins. During handling and testing, suitable ESD precautions must be taken.

Please note, that the sensor chip is not electrically isolated from the flow channel and the medium passing through it. Therefore, a voltage difference between sensor and medium should be avoided at all times through proper system grounding and design.

4. MICROFLUIDIC DRIVE SYSTEM

4.1. Performance

Figure 2 shows a logarithmic step-function in flow rate over four orders of magnitude: 3, 30, 300 and 3000 $\mu\text{L}/\text{min}$. At each step, flow is held for 30 seconds to demonstrate the flow control precision and stability. The time required to transition between steps is less than 2 seconds.

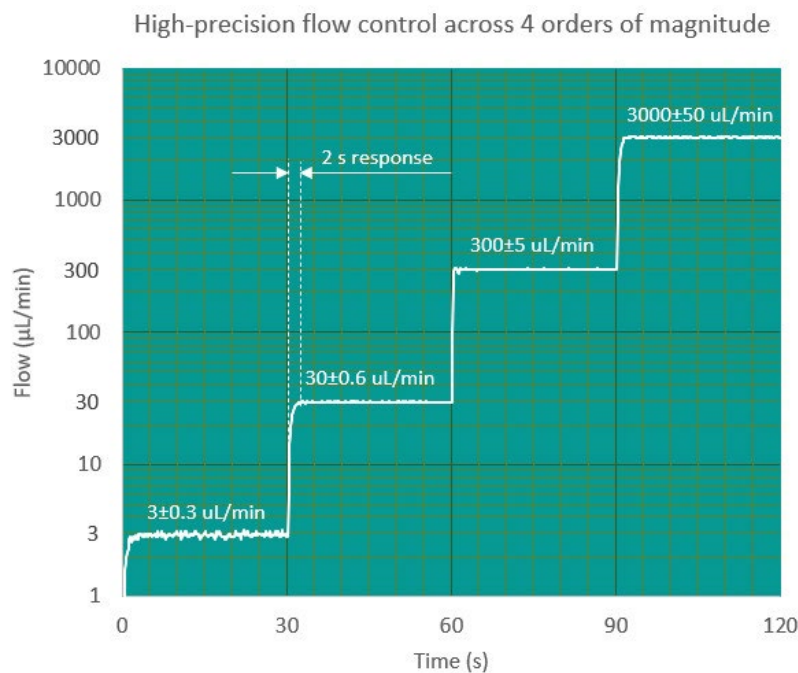

Figure 2. High precision flow control - Piezoelectric Disc Pump and Sensirion SLF3x series liquid flow sensor

4.2. What limits performance?

The maximum flow rate that can be achieved is determined by the maximum pneumatic pressure the pump can deliver, and a range of other factors including the liquid flow resistance through the system (e.g. as determined by the channel geometry and surface properties), the viscosity and surface tension of the fluid. The Lee Company offers a range of pumps to suit your pressure requirements.

The minimum flow rate, in principle, should be zero, as the disc pumps have no stall speed and therefore has a near-infinite turn-down ratio. The resolution of the pump output is also 'continuous'. In practice, both

the minimum flow rate and flow rate resolution are likely to be determined by the limits of the flow sensor and the pump drive electronics, rather than by the pump itself.

4.3. System components

- **Piezoelectric Disc Pump Evaluation Kit**, fitted, in this example with a UXPB5401000A pump¹.
- **Sensirion SLF3S-0600F flow sensor**, offering a 0 to ± 2000 $\mu\text{L}/\text{min}$ measurement range².
- **Liquid reservoir**—we used a Fluigent P-CAP Microfluidic Reservoir for a 15 mL Falcon Tube, but other reservoirs will work equally well.
- **Molex 151340602 cable assembly** to connect flow sensor to the Piezoelectric Disc Pump Evaluation Kit³.
- **Optional:** needle valve / bleed orifice between pump and reservoir (not shown in photo). This may be helpful for very low flow rate control and/or ability to stop liquid flow quickly, dependent on the specific system architecture.

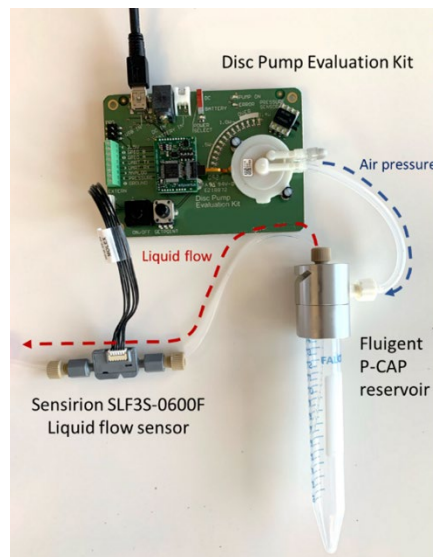

Figure 3. System components

¹ Other pump models are available to suit your requirements. Please refer to the disc pumps products section of The Lee Company website for more information on the available pump options and contact you Lee Sales Engineer for selection guidance.

² The Piezoelectric Disc Pump Evaluation Kit also supports the SLF3S-1300F and LD20 Series flow sensors from Sensirion. For further guidance on sensor selection, please contact Sensirion.

³ We recommend that the Molex 151340602 cable assembly is purchased *even when* the liquid flow sensor is procured as part of a Sensirion evaluation kit; the cables provided in the Sensirion evaluation kit are not compatible with the Piezoelectric Disc Pump Evaluation Kit without custom termination.

4.4. Ordering parts

The Lee Company only supplies the Piezoelectric Disc Pump Evaluation Kit shown in Figure 3. Please order the other components separately from their respective suppliers.

The SLF3x liquid flow sensors and flow sensor evaluation kits are available through Sensirion's worldwide distribution network <https://www.sensirion.com/en/distributor-search/>.

4.5. System schematic

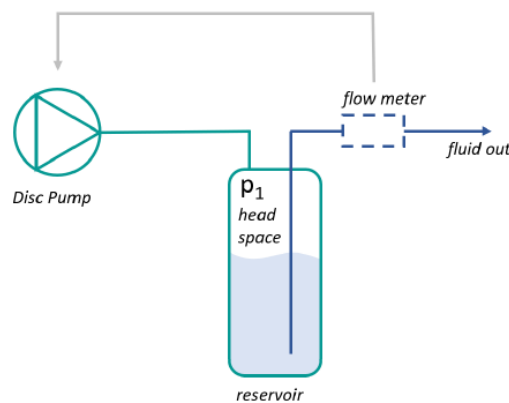

Figure 4. System schematic

4.6. System operation

The Lee Company has created firmware to communicate with and take measurements from the SLF3S-0600F, SLF3S-1300F and LD20 liquid flow sensors, and to operate closed-loop control of the flow rate.

To operate the system:

- Connect the components together per the schematic (Figure 4) and system photograph (Figure 3) before powering up.
- Connect the Piezoelectric Disc Pump Evaluation Kit to a PC with the supplied USB cable.
- Open the Disc Pump Control App supplied with the kit
 - Select the appropriate COM port and connect to the board
 - Select the PID control tab
 - Select your preferred flow rate setpoint source – we recommend using Manual, initially. *Please see the Piezoelectric Evaluation Kit User Manual for more information on setpoint sources.*
 - Select External Flow Sensor as the Input

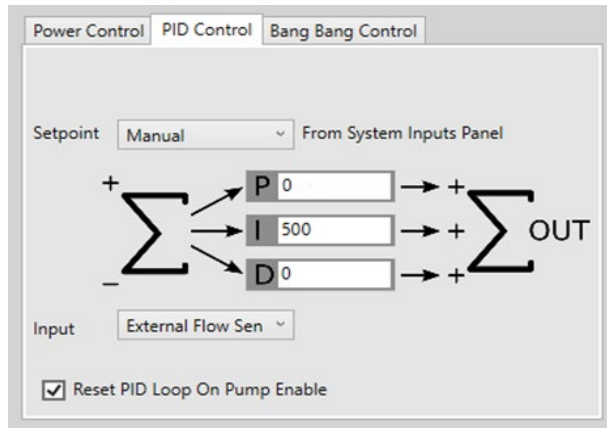

Figure 5. PID Control tab of the Disc Pump Control App

- Using the System Inputs panel, enter your desired flow rate into the Manual entry box, such as 1 ml/min as in the in Figure 6.

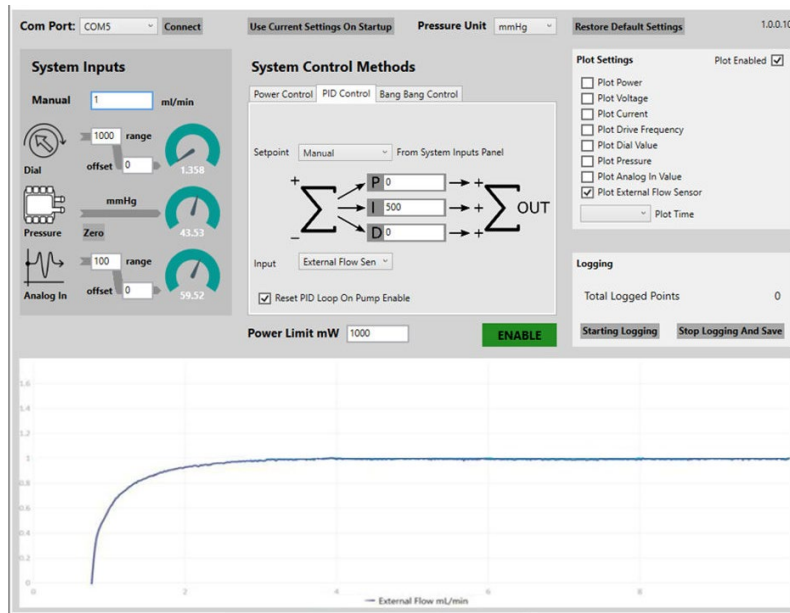

Figure 6. Disc Pump Control App

5. SUPPORT

5.1. Code snippet library

The Lee Company code snippet library, hosted on [GitHub](#), provides serial communication and control examples in Python for common functions, including turning the pump on and off, setting drive power, closed loop control of pressure and reading back and plotting data. The code snippet library implements the aspects of the communication protocol set out in resource: 'TG003: PCB Serial Communications Guide' and is intended to support customers after their initial evaluation of our pump technology, as they move on to developing prototypes and products.

5.2. Additional support

The Lee Company website provides advice on:

- Getting Started
- Applications
- Development Process
- Downloads (including datasheets, application notes, case studies and 3D models)
- Frequently Asked Questions

The Lee Company is happy to discuss next steps beyond prototyping, including system design. If you would like to discuss this with us, or for any other additional support, please you Lee Sales Engineer.

6. REVISION HISTORY

Date	Version	Change
June 23	230614	Rebranded & updated
14 May 2021	R210514	Update support, Figure 3 components and Sensirion models covered
25 September 2020	r200925	Corrections and clarifications.

30 July 2020	r200730	Initial release.
--------------	---------	------------------