

SMART PUMP
MODULE
(UxxCxxxxxxxx)
USER MANUAL

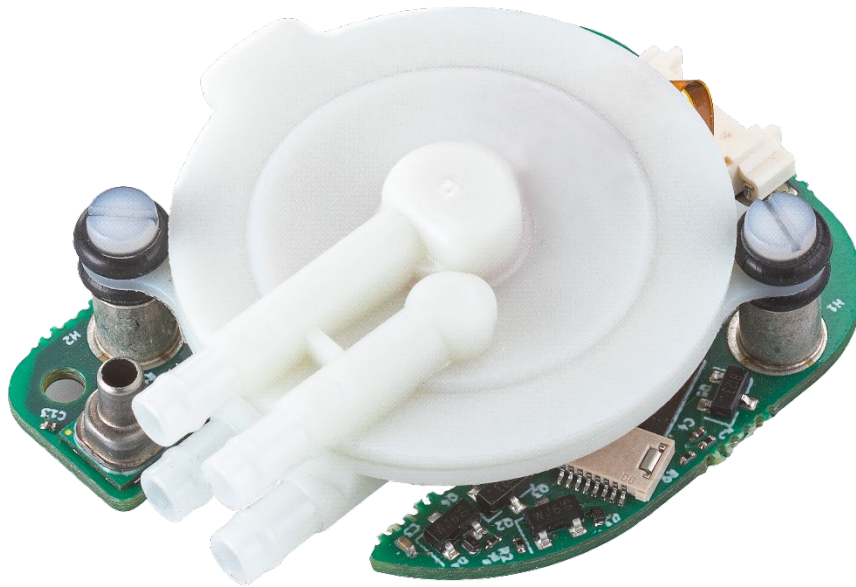



SMART PUMP MODULE (UxxCxxxxxxxx)

USER MANUAL

1.	DISCLAIMER	3
2.	SPECIAL NOTICES	3
3.	INTRODUCTION	4
3.1.	Piezoelectric Disc Pump	4
3.2.	The Smart Pump Module	5
4.	SAFETY	6
5.	MODULE OVERVIEW	7
6.	INSTALLATION	9
6.1.	Mechanical - SPM Mounting	9
6.2.	Pneumatic - Pump manifolding	10
6.2.1.	Inlet filtration requirements	10
6.2.2.	BL/XP/LT Series pumps	10
6.2.3.	HP Series pumps	16
6.3.	Electrical - SPM Connector	19
7.	SYSTEM OPERATION	20
7.1.	Preparing the system for first use	20
7.2.	System control interfaces	20
7.2.1.	Analog control	21

7.2.2.	Digital serial control	21
7.2.3.	UART / I2C auto-detection	21
7.3.	Configuring/controlling with the Power and Comms Cable.....	23
7.3.1.	Starting the Application	23
7.3.2.	System inputs.....	24
7.3.3.	System control methods.....	24
7.3.4.	Power Control mode	25
7.3.5.	PID control mode.....	25
7.3.6.	Bang Bang control mode (Positive pressure only).....	27
7.3.7.	Using the Analog Input.....	28
7.3.8.	Plotting	29
7.3.9.	Logging.....	29
7.3.10.	Power limit.....	30
7.3.11.	Saving Settings	30
8.	ACCESSORIES.....	31
8.1.	UACX0500400E (USB Power and Communications Cable)	31
8.2.	UACX0500600H (SPM Prototype Pneumatic Adaptor Kit).....	32
9.	SUPPORT	32
10.	CERTIFICATE OF CONFORMITY	33
11.	REVISION HISTORY	34

1. DISCLAIMER

This resource is provided "as is" and without any warranty of any kind, and its use is at your own risk. The Lee Company does not warrant the performance or results that you may obtain by using this resource. The Lee Company makes no warranties regarding this resource, express or implied, including as to non-infringement, merchantability, or fitness for any particular purpose. To the maximum extent permitted by law, The Lee Company disclaims liability for any loss or damage resulting from use of this resource, whether arising under contract, tort (including negligence), strict liability, or otherwise, and whether direct, consequential, indirect, or otherwise, even if The Lee Company has been advised of the possibility of such damages, or for any claim from any third party.

2. SPECIAL NOTICES

Throughout this User Manual, special notices relating to the safe and correct operation of the Smart Pump Module are formatted and highlighted as follows:



CAUTION

Instructions to ensure correct operation of the equipment and/or for avoiding damage to the equipment.



WARNING

Instructions relating to the safety of the operator and avoiding injury.

3. INTRODUCTION

3.1. Piezoelectric Disc Pump

The Lee Company's piezoelectric disc pumps are a multi-award-winning technology which makes use of advances in the field of non-linear acoustics to offer the following unique features:

- silent operation
- ultra-smooth flow
- millisecond responsiveness
- compact form factor
- high-precision controllability

In contrast to conventional air pumping mechanisms (such as diaphragm and piston pumps), the disc pumps do not rely on the bulk compression of air within a cavity. Instead, the disc pumps generate a high amplitude, high frequency acoustic standing wave within a specially designed acoustic cavity. The operating frequency varies part-to-part and with pump operating conditions (e.g. temperature, pressure, etc). A dedicated drive circuit is therefore required to identify and track this frequency over time.

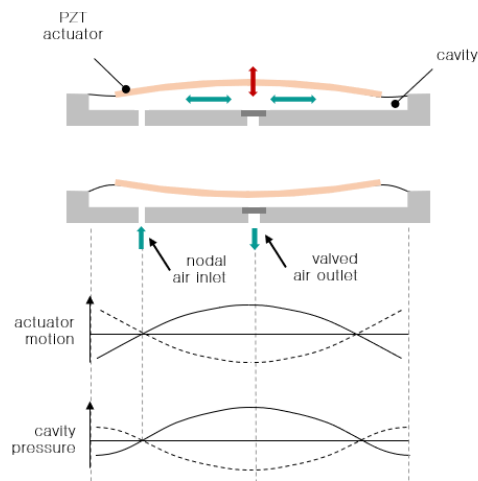

Figure 1. A schematic of the disc pump

Figure 1 shows a simplified schematic: the out-of-plane motion of the actuator drives in-plane (radial) motion of the gas in the cavity and creates a standing pressure wave, resulting in the oscillating cavity pressure shown. The motion of the actuator is highly exaggerated: there is virtually no net volume change of the cavity during operation and at any given point in time there exists both a region of compression and a region of rarefaction within the cavity.

Rectification of the alternating cavity pressure is the key to delivering useful pump performance and device lifetime. The Lee Company has addressed this need by developing a family of innovative valve designs based on lightweight polymer valve flaps.

The disc pump technology is protected by a portfolio of both patent applications and granted patents.

3.2. The Smart Pump Module

The Smart Pump Module combines a piezoelectric disc pump of your choice with drive electronics and pressure sensing in a tightly-integrated package. Its simple control interface, with digital and analog control options, makes the replacement of conventional pumps straightforward. This simplifies the design-in process, allowing OEMs to take advantage of the key benefits of the disc pumps, including silent operation and exceptional performance.

The Smart Pump Module offers standalone high-precision pressure and vacuum regulation, benefiting from the pulsation-free output, wide dynamic range and rapid response speed of the pump. The module can be fitted with any of the BL, XP, LT and HP Series pumps. Note that the Smart Pump Module is not compatible with US Series Disc Pump.

For the avoidance of doubt, the disc pumps can only pump air and similar gases directly; it cannot pump fluids directly. The disc pumps can however be employed in a wide range of liquid applications using the principle of pressure-driven flow. Please see Application Note: 'AN002: Microfluidics - Disc Pump Application Note' for more information.

This document provides details of the operation of the Smart Pump Module.

4. SAFETY

WARNING

The equipment described in this document is intended for use by skilled and competent personnel only. Further, the equipment is provided in a 'bare' format enabling users to integrate it into test fixtures, prototypes and product assemblies.

The user should satisfy themselves that the equipment is, and remains fit for, the intended use. The user accepts that The Lee Company shall not be held responsible or liable for any injury, damage or loss to property, person or otherwise, resulting from use of the equipment.



To aid in safety assessment of use of the equipment, the following indicative electrical data are provided:

A.C. voltage on the PCB: 120 Vpp max. (at 20 – 22 kHz)

D.C. voltage on the PCB: 60 V max.

All disc pumps emit ultrasound in operation. The following data are provided for operation at maximum power (1.4W) at a distance of 30cm:

Sound pressure level: 70-80 dB SPL @ 30 cm typ. (at 20-22 kHz)¹

1. Equivalent to <10 phon per ISO 226:2003 and related studies, 30 cm equivalent measurement distance

WARNING



Take care during use of the Smart Pump Module not to create short circuits between exposed conductive parts of the PCBs. Short circuits may lead to malfunctioning and heating.

5. MODULE OVERVIEW

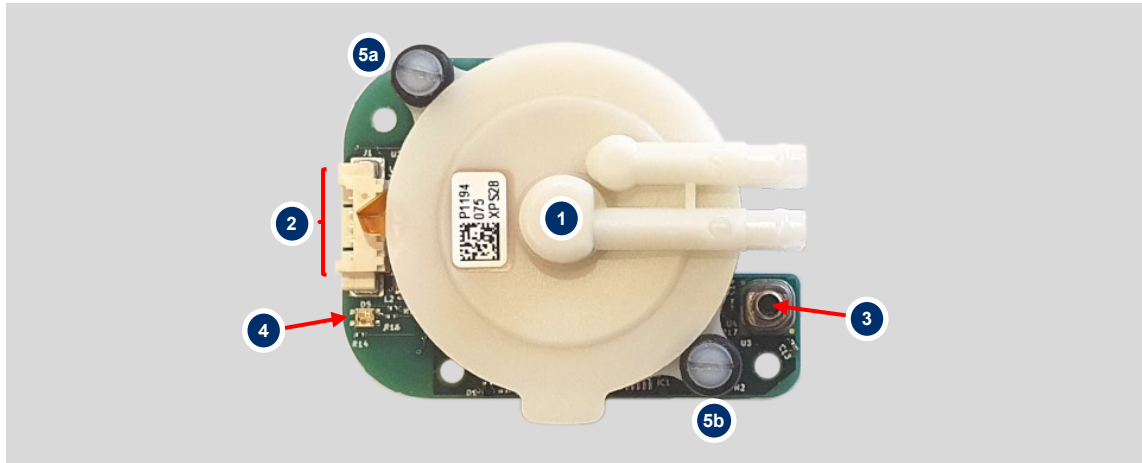
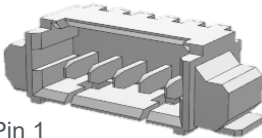
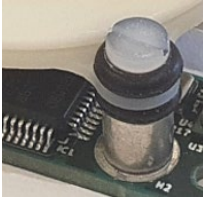

Figure 2. Smart Pump Module components

Item	Description	Details
1	Disc Pump	The Smart Pump Module can be ordered with BL, XP, LT and HP Series Disc Pumps. It is not compatible with US Series Disc Pumps.
2	Five-wire electrical interface	 <p>Pin 1</p> <p>Pin 5</p> <p>The SPM has a 5 pin, 1 Row, 1.25mm pitch Header (53261-0571) https://tinyurl.com/5ekymmev</p> <p>Pinout:</p> <ul style="list-style-type: none"> 1 - VCC - 3.5 to 5.5 V supply 2 - UART RX / I2C SDA (3.3V) 3 - UART TX / I2C SCL (3.3V) 4 - Ground

		5 - 0 to 3.3 V Analog In								
3	On-board pressure sensor	Supports greater than -400 mBar to +600 mBar (gauge) 12-bit resolution Update rate approx. 60 Hz.								
4	Indicator LED	<table border="1"> <thead> <tr> <th>Colour / indication</th> <th>Module status</th> </tr> </thead> <tbody> <tr> <td>Green, breathing</td> <td>Idle</td> </tr> <tr> <td>Orange</td> <td>Pump running</td> </tr> <tr> <td>Red, flashing</td> <td>Module in error</td> </tr> </tbody> </table>	Colour / indication	Module status	Green, breathing	Idle	Orange	Pump running	Red, flashing	Module in error
Colour / indication	Module status									
Green, breathing	Idle									
Orange	Pump running									
Red, flashing	Module in error									
5	Pump mounts	 <p>Note use of O-rings and nylon bolts to isolate high-frequency vibration and prevent audible noise.</p>								

6. INSTALLATION

6.1.Mechanical - SPM Mounting

The SPM PCB has three 2.2 mm diameter mounting holes provided, as shown below. In order to isolate high-frequency vibration and prevent audible noise, it is recommended that the SPM is mounted using nylon M2 screws, using nylon washers or standoffs to maintain a clearance to the underside of the PCB.

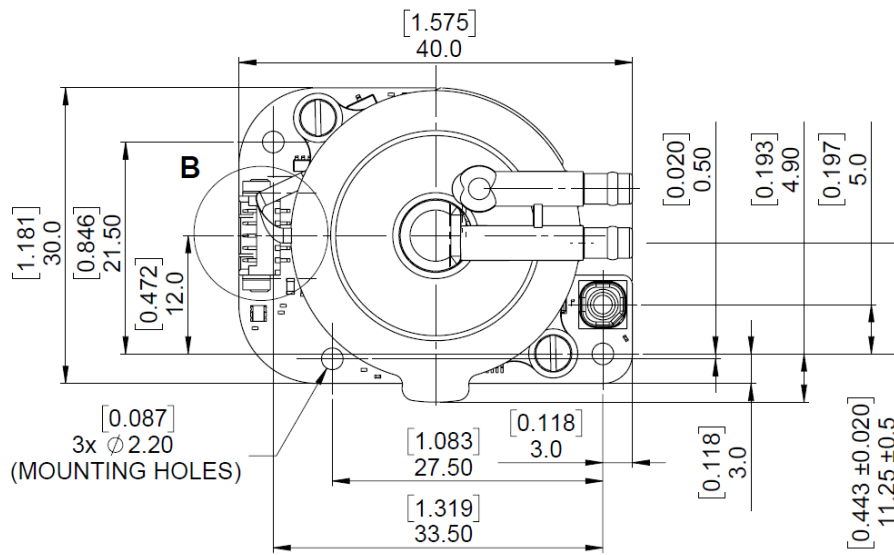

Figure 3: SPM Geometry. Dimensions in mm [inches]

6.2. Pneumatic - Pump manifolding

6.2.1. Inlet filtration requirements

TAKE NOTE



All disc pumps should be operated with an inlet filter to prevent ingestion of debris that might otherwise shorten the operational life of the pump. The Lee Company recommends that a non-shedding filter with a pore size less than 3 microns is used.

6.2.2. BL/XP/LT Series pumps

- Take note of the pump configuration according to the pump labelling:

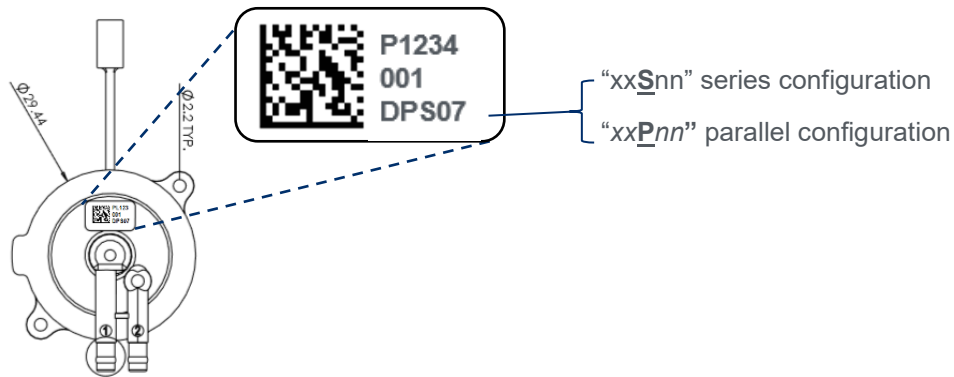

Figure 4. Identifying the pump by the label

6.2.2.1. BL/XP/LT Series pumps - series configuration pumps

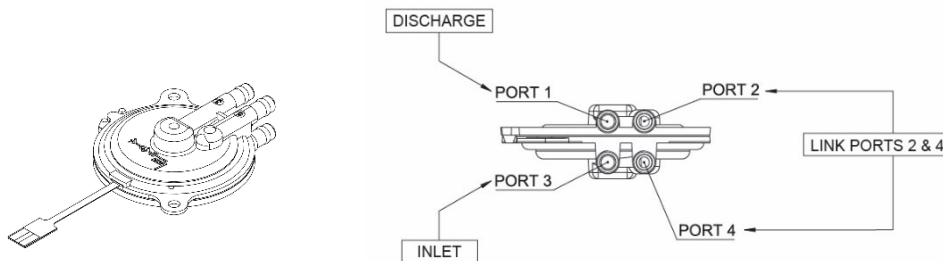

Figure 5. BL/XP/LT Series, series configuration pumps - port numbering

For series configuration pumps:

- Ports 2 and 4 must be linked (see the pump [Accessories](#) for suggested coupler)
- Port 3 is inlet
- Port 1 is discharge

Positive pressure regulation

Where the user intends to use the module to regulate pressure or vacuum, an additional connection should be made to the onboard pressure sensor.

For positive pressure regulation, connect Port 1 to the pressure sensor and the downstream system using a ‘T’ or ‘Y’ connector.

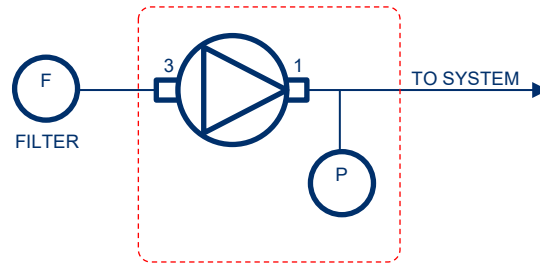

Figure 6. Schematic for connecting a series configuration pump for positive pressure regulation

The optional extra SPM Prototype Pneumatic Adapter Kit (UACX0500600H) can be purchased for prototyping and development purposes. This kit includes a 'C' coupler, 'Y' coupler and right-angled pressure sensor pipe for convenient connection between the pump and pressure sensor. Note that these components are fabricated by SLA and are therefore not recommended for use in mass-produced products.

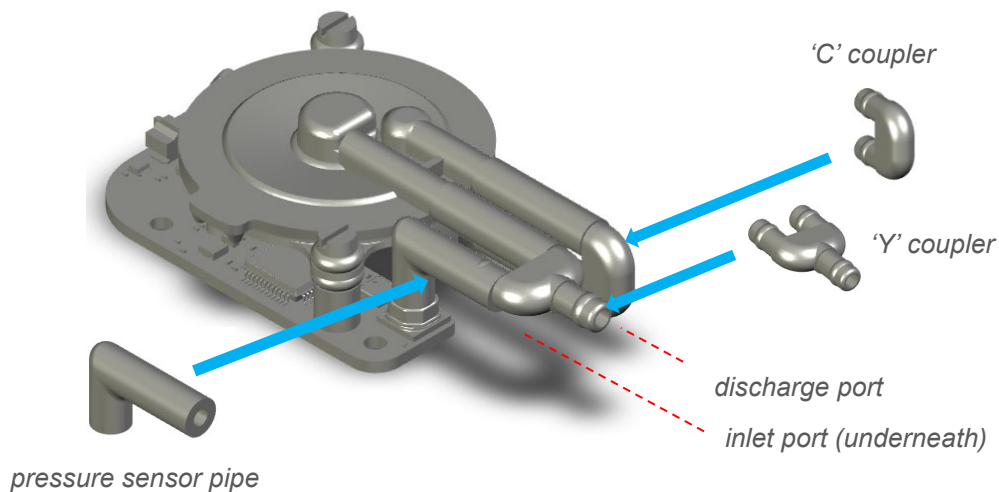

Figure 7. Connecting a series configuration pump for positive pressure regulation with the prototype connectors supplied with the optional SPM Prototype Pneumatic Adapter Kit (UACX0500600H)

Vacuum pressure regulation

For vacuum pressure regulation, connect Port 3 to the pressure sensor and the upstream system using a 'T' or 'Y' connector.

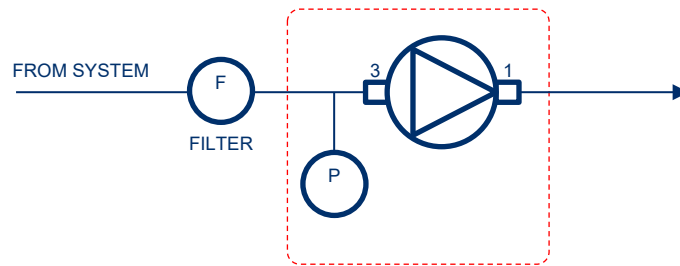

Figure 8. Schematic for connecting a series configuration pump for vacuum pressure regulation

The optional extra SPM Prototype Pneumatic Adapter Kit (UACX0500600H) can be purchased for prototyping and development purposes. This kit includes a right-angled 'Y' coupler and right-angled pressure sensor pipe for convenient connection between the pump and pressure sensor. Note that these components are fabricated by SLA and are therefore not recommended for use in mass-produced products.

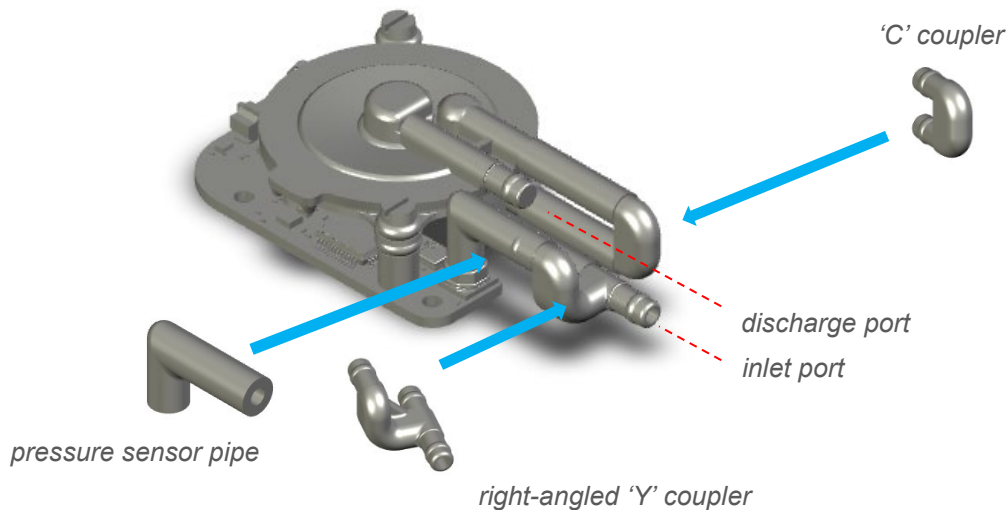

Figure 9. Connecting a series configuration pump for vacuum pressure regulation with the prototype connectors supplied with the optional SPM Prototype Pneumatic Adapter Kit (UACX0500600H)

6.2.2.2. BL/XP/LT Series pumps – parallel configuration pumps

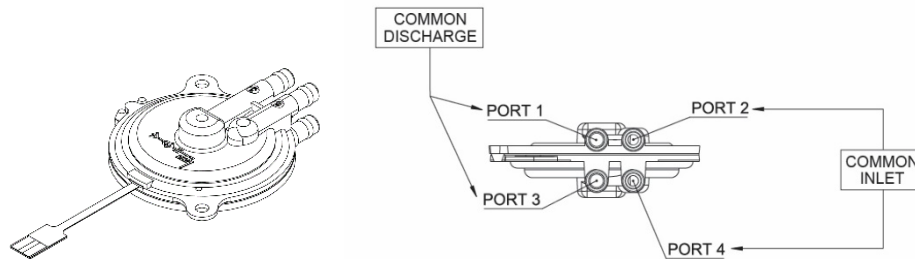

Figure 10. BL/XP/LT Series, parallel configuration pumps - port numbering

For parallel configuration pumps:

- Ports 2 and 4 are the common inlet and should be linked*
- Ports 1 and 3 are the common discharge and should be linked *
* (see the pump [Accessories](#) for suggested coupler)

Positive pressure regulation

Where the user intends to use the module to regulate pressure or vacuum, an additional connection should be made to the onboard pressure sensor.

For positive pressure regulation, connect Port 1 and Port 3 to the pressure sensor and the downstream system using a ‘T’ or ‘Y’ connector.

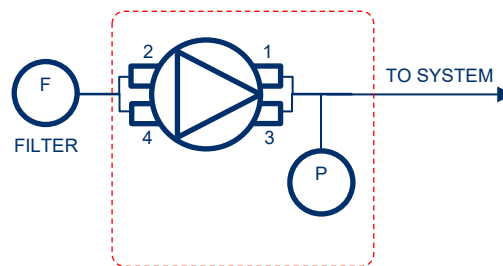

Figure 11. Schematic for connecting a parallel configuration pump for positive pressure regulation

The optional extra SPM Prototype Pneumatic Adapter Kit (UACX0500600H) can be purchased for prototyping and development purposes. This kit includes a positive pressure adapter (identified with a single

circular dot on top of the part) and right-angled pressure sensor pipe for convenient connection between the pump and pressure sensor. Note that these components are fabricated by SLA and are therefore not recommended for use in mass-produced products.

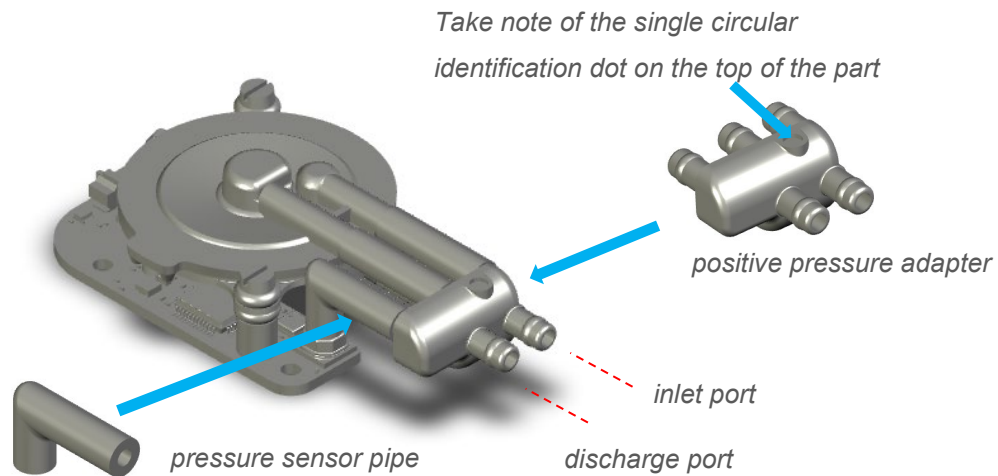

Figure 12. Connecting a parallel configuration pump for positive pressure regulation with the prototype connectors supplied with the optional SPM Prototype Pneumatic Adapter Kit (UACX0500600H)

Vacuum pressure regulation

For vacuum pressure regulation, connect Port 2 and Port 4 to the pressure sensor and the upstream system using a 'T' or 'Y' connector.

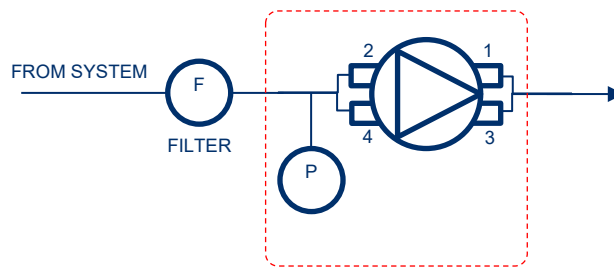

Figure 13. Schematic for connecting a parallel PDC pump for vacuum pressure regulation

The optional extra SPM Prototype Pneumatic Adapter Kit (UACX0500600H) can be purchased for prototyping and development purposes. This kit includes a vacuum adapter (identified with two circular dots

on top of the part) and right-angled pressure sensor pipe for convenient connection between the pump and pressure sensor. Note that these components are fabricated by SLA and are therefore not recommended for use in mass-produced products.

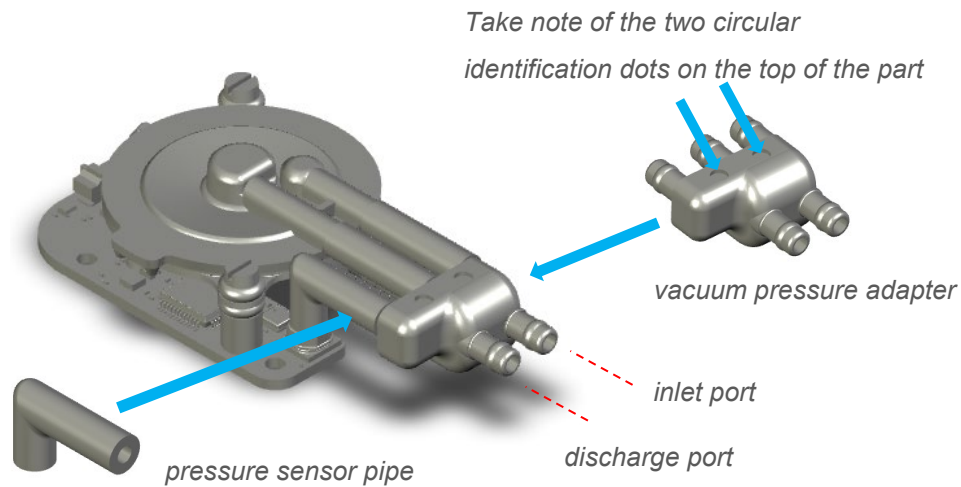

Figure 14. Connecting a parallel configuration pump for vacuum pressure regulation with the prototype connectors supplied with the optional SPM Prototype Pneumatic Adapter Kit (UACX0500600H)

6.2.3. HP Series pumps

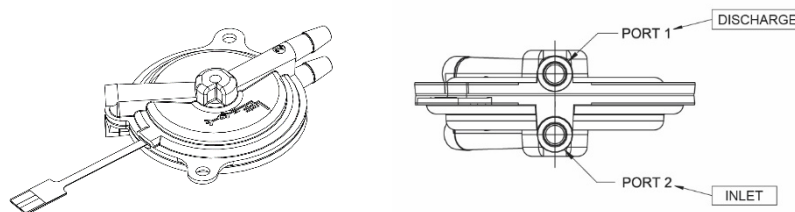

Figure 15. HP Series pumps - port numbering

For HP Series pumps:

- Ports 2 is the inlet
- Ports 1 is the discharge

Positive pressure regulation

Where the user intends to use the module to regulate pressure or vacuum, an additional connection should be made to the onboard pressure sensor.

For positive pressure regulation, connect Port 2 to the pressure sensor and the downstream system using a ‘T’ or ‘Y’ connector.

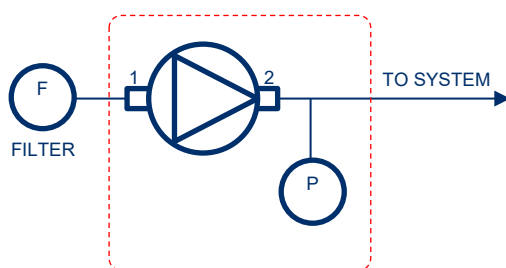

Figure 16. Schematic for connecting an HP Series pump for positive pressure regulation

The optional extra EK-03-0052 SPM Prototype Pneumatic Adapter Kit can be purchased for prototyping and development purposes. This kit includes a ‘Y’ coupler and right-angled pressure sensor pipe for convenient connection between the pump and pressure sensor. Note that these components are fabricated by SLA and are therefore not recommended for use in mass-produced products.

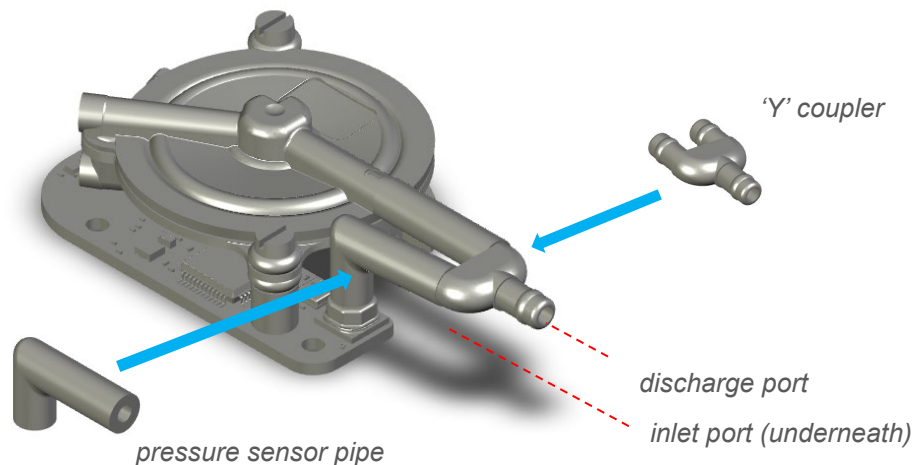

Figure 17. Connecting an HP Series pump for positive pressure regulation with the prototype connectors supplied with the optional SPM Prototype Pneumatic Adapter Kit (UACX0500600H)

Vacuum pressure regulation

For vacuum pressure regulation, connect Port 1 to the pressure sensor and the upstream system using a 'T' or 'Y' connector.

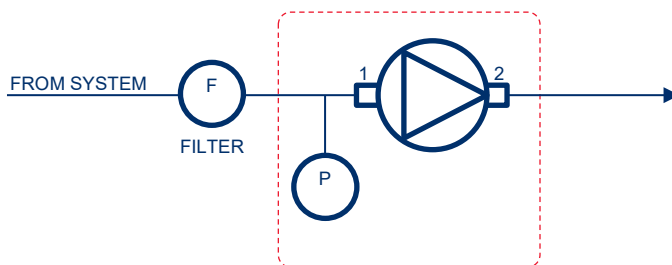

Figure 18. Schematic for connecting an HP Series pump for vacuum pressure regulation

The optional extra SPM Prototype Pneumatic Adapter Kit (UACX0500600H) can be purchased for prototyping and development purposes. This kit includes a right-angled 'Y' coupler and right-angled

pressure sensor pipe for convenient connection between the pump and pressure sensor. Note that these components are fabricated by SLA and are therefore not recommended for use in mass-produced products.

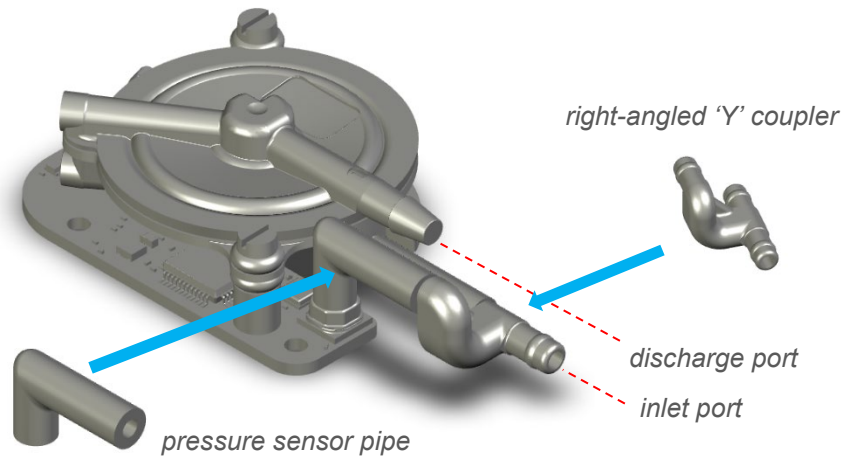
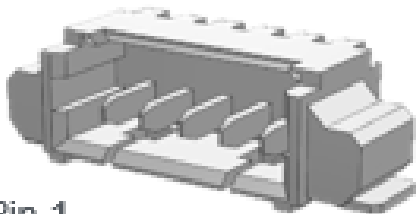

Figure 19. Connecting an HP Series pump for vacuum pressure regulation with the prototype connectors supplied with the optional SPM Prototype Pneumatic Adapter Kit (UACX0500600H)

6.3.Electrical - SPM Connector

The connector on the SPM is a 5 pin, 1 Row, 1.25mm pitch Header (53261-0571):

<https://tinyurl.com/5ekymmev>



Pin 1

Pin 5

The pinout is as follows

- 1 - VCC - 3.5 to 5.5 V supply
- 2 - UART RX / I2C SDA (3.3V)
- 3 - UART TX / I2C SCL (3.3V)
- 4 – Ground
- 5 – 0 to 3.3 V Analog In

The Power and Communication Cable (UACX0500400E) is an optional extra that can be purchased from The Lee Company (~2m in length). The Power and Communication Cable enables Smart Pump Module devices to be connected by USB to provide power and Serial Communications. It also allows the SPM to be connected to the Disc Pump Control App.

7. SYSTEM OPERATION

7.1. Preparing the system for first use

- Remove the module from protective ESD bag.
- Connect the pump ports (see §6.2).
- Connect the electrical supply and communications (see §6.3).

7.2. System control interfaces

The system provides two control interfaces: 0 to 3.3 V analog control; and digital serial control. The default configuration of all Smart Pump Module when shipped is analog control of pump drive power, as described in §7.2.1.

7.2.1. Analog control

Pin 5 of the Smart Pump Module connector is a 0 to 3.3 V analog input (see §6.3). The analog input can be configured to control pump drive power (“open-loop” control) or to set the target pressure flow when using the module for standalone pressure or vacuum regulation (“closed-loop” PID control).

The default configuration of all Smart Pump Modules when shipped is analog control of pump drive power:

0 to 3.3 V input = 0 to 1 W pump drive power

It is possible to remap the analog input, such that 0 to 3.3 V input maps to an arbitrary output power range, e.g.

0 to 3.3 V input = 0.3 to 0.7 W pump drive power

This mapping can be configured via the digital serial interface either UART or I2C. Refer to The Lee Company Technical Guide ‘TN003 Serial Communications Guide’ for more information. Additionally, where UART is used, the Disc Pump Control App can be used to configure this mapping. See §7.3.4 and §7.3.5 for more information.

7.2.2. Digital serial control

The Smart Pump Module implements both UART and I2C interfaces to enable digital serial control. Refer to The Lee Company Technical Guide ‘TN003 Serial Communications Guide’ for more information on the configuration and command set of these two control options.

7.2.3. UART / I2C auto-detection

The Smart Pump Module has an auto-detection function that runs on start up to establish whether the module is connected to an I2C bus, or directly to a master device via UART. The module does this by checking whether a strong pull-up resistor (≤ 10 kOhm) is connected to the UART TX / I2C SCL line. The SPM attempts to pull this line down weakly. If it succeeds, the UART interface is selected; otherwise, the I2C interface is selected.

For a UART connection, the SPM expects the UART TX line (pin 3 on the connector – see §6.3) to be connected to a high impedance input, although a pull-up resistor can be used providing the value is greater than 100 kOhm. Alternatively, a pull-down resistor can be fitted.

For an I2C connection, the SPM expects the I2C SCL line (pin 3 on the connector – see §6.3) to have pull-up resistor of 10 kOhm or lower fitted.

Figure 20 presents a schematic of the two configuration options required for the UART / I2C auto-detection function.

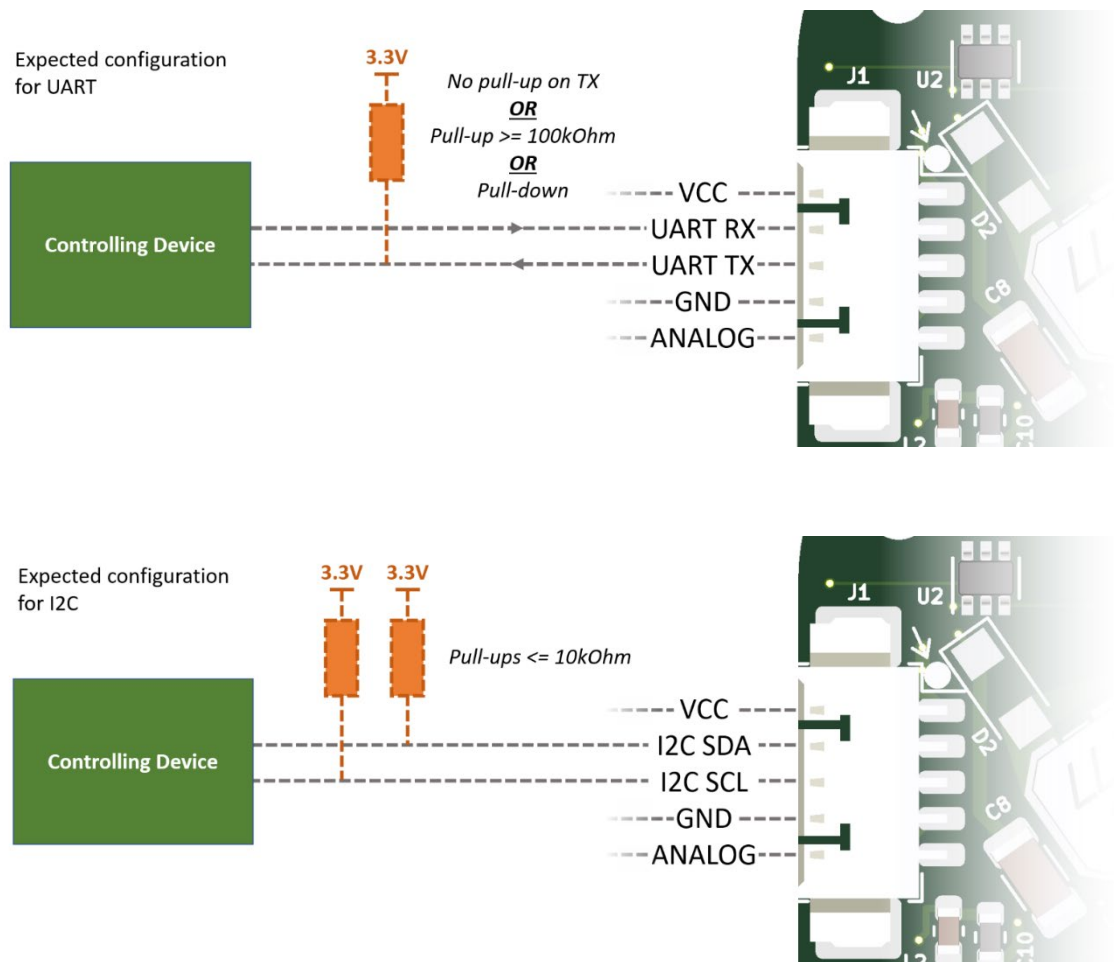

Figure 20: Expected pull-up resistor configurations required for UART / I2C auto-detection function

7.3. Configuring/controlling with the Power and Comms Cable

The Power and Communication Cable (UACX0500400E) is an optional extra that can be purchased from The Lee Company (~2m in length). The Power and Communication Cable enables Smart Pump Module devices to be configured and controlled with the Disc Pump Control App.

To install the application:

- Copy the Disc Pump Control App folder from the USB flash drive (if purchased) to a destination folder on the target PC. Alternatively download the Disc Pump Control App from The Lee Company website.

To download the relevant drivers:

- Ensure the PC is connected to the internet.
- Connect the PCB to the PC with the USB cable.
- If the PC is running Windows 7 or later, all drivers should automatically be downloaded and installed.
- Drivers can be download from here: <https://ftdichip.com/drivers/vcp-drivers/>



CAUTION

Ensure that the driver installation process has completed successfully before proceeding

7.3.1. Starting the Application

Double click on the “Disc Pump Control App.exe” executable file.

- Select the appropriate COM port from the top-left dropdown menu and click connect.
- The application should now be connected and display all the current settings on the GUI.

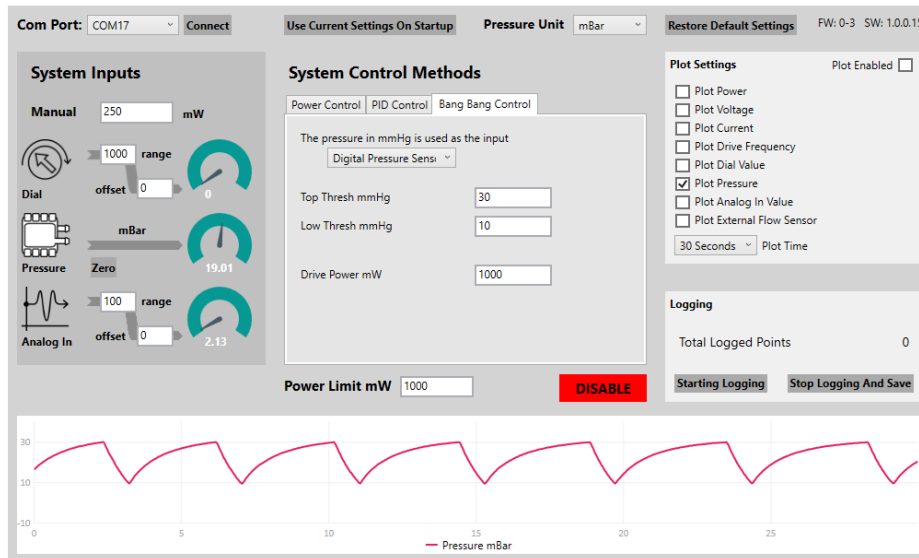

Figure 21: Disc Pump Control App GUI

7.3.2. System inputs

The user interface has a panel displaying the System Inputs on the left-hand side – these are: a manual setpoint entered via the software; the digital pressure sensor; and a 0 to 3.3 V analog input. Note that the “Dial” input is not available for SPM modules (this is a feature of the Disc Pump Evaluation Kit). The values for these inputs are displayed under the green dials on the user interface.

The analog in input has a range and an offset associated with it. This allows this input to be arbitrarily mapped to power and pressure setpoint variables. Use of the range and offset values is explained in §7.3.4 and §7.3.5.

7.3.3. System control methods

In the centre of the user interface is the System Control Methods panel. There are three control modes – power control, PID pressure control, and bang-bang pressure control.

7.3.4. Power Control mode

Power Control mode controls the drive power supplied to the pump.

- Select the Power Control tab.
- Select the target power source from the dropdown menu:
 - **Manual:** the power target is entered manually into the “System Input” section. The units are milliwatts.
 - **Potentiometer:** not available for SPM modules (this is a feature of the Disc Pump Evaluation Kit)
 - **Analog Input:** the power target is controlled by the 0 to 3.3V analog input supplied via pin 5 of the five-wire electrical interface.
 - Note that the analog in control input value is displayed in the “System Inputs” section of the PC application. It has a range and offset associated with it, allowing the mapping of the input to the target power to be configured.

- Example mappings:

Desired full-scale range mapping	Range	Offset
0 to 1000 mW	1000	0
0 to 500 mW	500	0
200 to 400 mW	200	200

Table 1: Example mappings of the Range and Offset variables

- Click the “Enable/Disable” button on the GUI to toggle the pump output.
- Tick the “Plot Power” check box to observe the drive power supplied to the pump.

7.3.5. PID control mode

PID Control mode adjusts the pump drive power until a target pressure/vacuum is reached.



TAKE NOTE

Connect the pressure sensor to the circuit according to §6.2.2 and §6.2.3 prior to using pressure/vacuum regulation.

For positive pressure control, connect the pressure sensor to the outlet of the pump, and use positive pressure setpoint targets and positive values for the P, I and D coefficients.

For negative pressure control, connect the pressure sensor to the inlet to the pump, and use negative pressure setpoint targets and negative values for the P, I and D coefficients.

The pressure sensor reading can be zeroed by clicking the “Zero” button next to the pressure sensor icon. The zero offset can be reset by clicking “Restore Default Settings”.

- Select the PID Control tab.
- Select the pressure control setpoint from the dropdown menu:
 - **Manual:** the pressure target is entered manually into the “System Input” section
 - **Dial:** not available for SPM modules (this is a feature of the Disc Pump Evaluation Kit)
 - **Analog Input:** the power target is controlled by the 0 to 3.3V analog input supplied via pin 5 of the five-wire electrical interface.
 - Note that the analog control input value is displayed in the “System Inputs” section of the PC application. It has a range and offset associated with it, allowing the mapping of the input to the target pressure to be configured.

- Example mappings for the analog input control are:

Desired full-scale range mapping	Range	Offset
0 to 100 mmHg	100	0
0 to 200 mmHg	200	0
100 to 200 mmHg	100	100

Table 2: Example mappings of the Range and Offset variables

- **Input:** Select ‘Digital Pressure Sensor’ from the drop-down list

- Click the “Enable/Disable” button on the GUI to toggle the pump output.
- Tick the “Plot Pressure” check box to observe the pressure measured by the sensor.
- The P, I and D coefficients should be configured to optimise performance of the loop for the customer’s specific setup. Factors such as the volume of the pneumatic circuit need to be considered when tuning the pressure control loop.



Figure 22. Pressure controlled to 50 mmHg under PID control mode

7.3.6. Bang Bang control mode (Positive pressure only)

“Bang Bang” control mode is a simple on-off controller that switches the pump on and off to control the output pressure between two defined pressure limits. Bang bang control is not possible in the vacuum regulation setup with the SPM.



TAKE NOTE

Connect the pressure sensor to the circuit according to §6.2.2 and §6.2.3 prior to using pressure regulation.

- Select the Bang Bang Control tab.
- Enter the upper pressure limit in the Top Thresh field.

- Enter the lower pressure limit in the Low Thresh field.
- Enter a value for Drive Power mW – this is the drive power supplied to the pump when it is on; if in doubt, start with 1000, but back this off if pressure overshoot above the upper threshold is an issue, or to reduce the rate of inflation.
- Click the “Enable/Disable” button on the GUI to toggle the pump output. Alternatively, use the ON/OFF button on the motherboard.
- Tick the “Plot Pressure” check box to observe the pressure measured by the sensor.



Figure 23: Pressure cycling between two limits under bang-bang control.

7.3.7. Using the Analog Input

The analog input can be used in a variety of ways to deliver external control of pump performance. This can be useful for initial system integration work, for example.

To control pump power The analog input can be used to variably control the pump drive power. See §7.3.4 for further details.

<p>To 'gate' the pump drive for short pulse control</p>	<p>The analog input is sampled at around 1kHz, enabling the pump to be switched on and off quickly to any desired power level using power control mode (see §7.3.4). This feature can be used to deliver a short pulse of air, e.g. for microfluidic control applications.</p>
<p>To control the output pressure setpoint</p>	<p>The analog input can be used to provide the target pressure for the on-board PID control loop, with the on-board pressure sensor being used to monitor the actual pressure. See §7.3.5 for further details.</p>
<p>As an input from an external pressure sensor</p>	<p>The analog input can be used as an input from an external pressure sensor to the on-board PID control loop, with the target pressure set manually or via the software. See §7.3.5 for further details.</p>

7.3.8. Plotting

Various parameters can be plotted on the graph presented in the PC application.

- In the Plot Settings panel, tick the Plot Enabled check box.
- Tick the check boxes for the values to be plotted.
- Select the Plot Time from the dropdown menu – this is the maximum duration of data displayed in the graph.
- It is possible to zoom on the graph by scrolling whilst hovering over it with the mouse cursor.
- Panning up and down the Y axis is possible by clicking and dragging up and down.
- The value at a given point for a given curve on the graph can be displayed by rolling over the point.

7.3.9. Logging

Data can be logged to a CSV file for offline analysis.

- In the Logging panel, click the Start Logging button.
- Observe that the Total Points Logged counter is increasing.
- When finished, click the Stop Logging And Save button.

7.3.10. Power limit

The Smart Pump Module has a function to limit the drive power supplied to the pump to prevent damage to the pump. The Power Limit mW field allows this limit to be set. Initially, we recommend that this limit is set to 1000 mW. For intermittent (i.e. non-continuous) use, higher limits can be used up to a maximum of 1400 mW. Intermittent use is defined as having:

- Mean power \leq 1000 mW
- A duty cycle period of less than 20 s.

7.3.11. Saving Settings

It is possible to save the Smart Pump Module settings to be used at start up (when the system is next powered). To do this, click the “Use Current Settings On Start-up” button.

8. ACCESSORIES

The following accessories are available for the SPM:

8.1.UACX0500400E (USB Power and Communications Cable)

The UACX0500400E USB Power and Communication Cable is an optional extra that can be purchased from The Lee Company. The Power and Communication Cable enables SPM Smart Pump Module devices to be configured and controlled with the Disc Pump Control App.

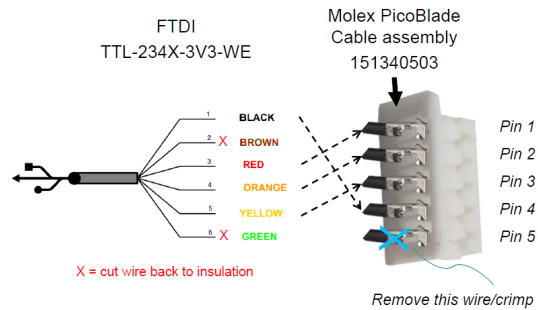

Figure 24: Part UACX0500400E

Notes:

- Connector 1: USB A
- Connector 2 : 5 pin Molex PicoBlade Cable Assembly
- Length: 2 m

8.2.UACX0500600H (SPM Prototype Pneumatic Adaptor Kit)

The adaptor kit provides a number of connectors to provide a convenient method for linking ports in a range of SPM prototype systems.

ITEM NO.	DESCRIPTION
1	Manifold - PDC (-) pressure
2	Manifold - PDC (+) pressure
3	Manifold - SDC & HP (-) pressure
4	L tube
5	Y Coupler
6	SPM Silicone Tube - Pre Cut
7	C Coupler

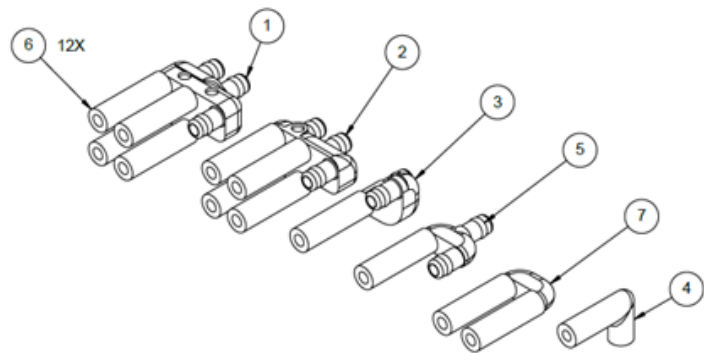

Figure 25: Part UACX0500600H

Materials: Accura Extreme Polymer and Silicone

Notes: Note that these prototype components are fabricated by SLA and are therefore not recommended for use in mass-produced products. The Lee Company make no guarantees concerning the performance of this component with respect but not limited to:



- Burst pressure
- Working pressure
- Materials/environmental compatibility
- UV exposure

9. SUPPORT

The Lee Company website <http://www.theleeco.com/discpumps> provides technical information, FAQs, troubleshooting and documentation for download.

For additional technical support, please contact your Lee Sales Engineer.

10. CERTIFICATE OF CONFORMITY

	<p>LEE Ventus Limited Melbourn Science Park Melbourn Hertfordshire SG8 6EE United Kingdom</p>
<p><u>EC and UKCA Declaration of Conformity</u></p>	
	
<p><u>Products:</u></p>	<p>Piezoelectric disc pumps and related modules, drive electronics and accessories</p>
<p><u>Models:</u></p>	
<p>Piezoelectric disc pumps</p>	<p>UBLB5xxxxxxx (BL Series Disc Pumps) , UXPB5xxxxxxx (XP Series Disc Pumps), UHPB5xxxxxxx (HP Series Disc Pumps) , UHPB5xxxxxxx (US Series Disc Pumps)</p>
<p>Piezoelectric disc pump modules</p>	<p>UxxC5xxxxxxx (Smart Pump Modules incorporating any of the XP, BP, LT or HP Pump Series)</p>
<p>Drive electronics and accessories</p>	<p>UEKA0300000A (General Purpose Disc Pump Driver), UEKA0300050A (Evaluation Kit Motherboard), UACX0500100E (Breakout Board), UACX0500400E (SPM Communication Cable)</p>
<p>Serial numbers:</p>	<p>See label on product</p>
<p><u>Manufacturer:</u></p>	<p>LEE Ventus Ltd, Melbourn Science Park, Royston, Herts, SG8 6EE, UK</p>
<p><u>EU Authorised Representative:</u></p>	<p>The Lee Company Scandinavia AB, Stormbyvägen 2-4, 163 55 Spånga, Sweden</p>
<p>We hereby declare that the products above comply with all relevant provisions of the following directives:</p>	
<ul style="list-style-type: none"> • Restriction of Hazardous Substances Directive 2011/65/EU • The Restriction of the Use of Certain Hazardous Substances in Electrical and Electronic Equipment Regulations 2012 No. 3032 	
<p>The products have been evaluated in accordance with the following harmonised standards:</p>	
<ul style="list-style-type: none"> • EN IEC 63000:2018 	
<p>A technical file for each product is retained at the manufacturer's address.</p>	
<p>Signed</p>	
<p>Name:</p>	<p>Tom Harrison</p>
<p>Position:</p>	<p>Managing Director</p>
<p>P-2-058 Declaration of Conformity v01</p>	

11. REVISION HISTORY

Revision	Date	Details
V01	June 2023	Branding changes inclusion of accessories and certificate of conformity
220608	8 June 2022	Select Digital Pressure Sensor on the Input drop down list for PID control
220425	25 April 2022	Added guidance on UART / I2C auto-detection and further details on EK-03-0052 SPM Prototype Pneumatic Adapter Kit
220414	14 April 2022	Various: UART/I2C voltage, connector pin identity, SLA advice update, U and I versions no longer applicable.
220304	4 March 2022	Initial release.