

Installation Procedure IP 2.5 mm Press-In F

REVISION HISTORY

Revision	Date	Change
A	7/1/2022	Initial Release
B	8/21/2023	Update

*Installation Procedure, Lee Check Valve,
 2.5 mm, Press-In for Forward Flow*

FACTORY INSTALLATION PROCEDURE

Table of Contents

1. OVERVIEW..... 2

2. INSTALLATION HOLE REQUIREMENTS 2

3. INSTALLATION..... 3

INSTALLATION OVERVIEW 3

FACTORY BEST PRACTICES 3

4. APPENDICES..... 4

APPENDIX A: INSTALLATION HOLE DIMENSIONS..... 4

APPENDIX B: INSTALLATION TOOL DIMENSIONS..... 4

1. Overview

This procedure is intended to provide process guidelines for proper installation of Lee Check Valve, 2.5 mm, Press-In product in forward flow orientation. Section 2 provides an overview of the installation hole requirements. Section 3 contains the installation procedure and customer assembly process recommendations. Section 4 contains reference information on the installation hole and installation tool.

Compliance with this installation procedure will ensure optimal product performance. Please contact your local Lee Company Sales Representative for questions concerning installation of Lee Company products.

2. Installation Hole Requirements

The Lee Check Valve, 2.5 mm, Press-In product is designed for installation into plastic manifolds or fittings and to perform well under adverse conditions.

Installation hole specifications, as found on Lee Installation Hole Drawing 1INST012735S (Appendix A), will ensure proper operation of the Lee Check Valve, 2.5 mm, Press-In product. The hole should be clean, dry, and free of burrs/flash. The series of smoothly curved lands of the Lee Check Valve, 2.5 mm, Press-In product allow the valve to be pressed in while the plastic flows into the adjacent grooves. Some plastics with sufficient elongation, such as Polypropylene, Nylon, Acetal, Polyethylene and PEEK, cold flow into the grooves providing retention and sealing.

Rigid plastics, such as acrylic and polycarbonate, have the risk of cracking from the stress of the interference installation. For installation into these types of plastics contact your local Lee Company Sales Representative for more information.

3. Installation

Installation Overview for Forward Flow Installation

1. For forward flow applications the Lee Check Valve, 2.5 mm, Press-In product is inserted into the installation hole oriented as shown.

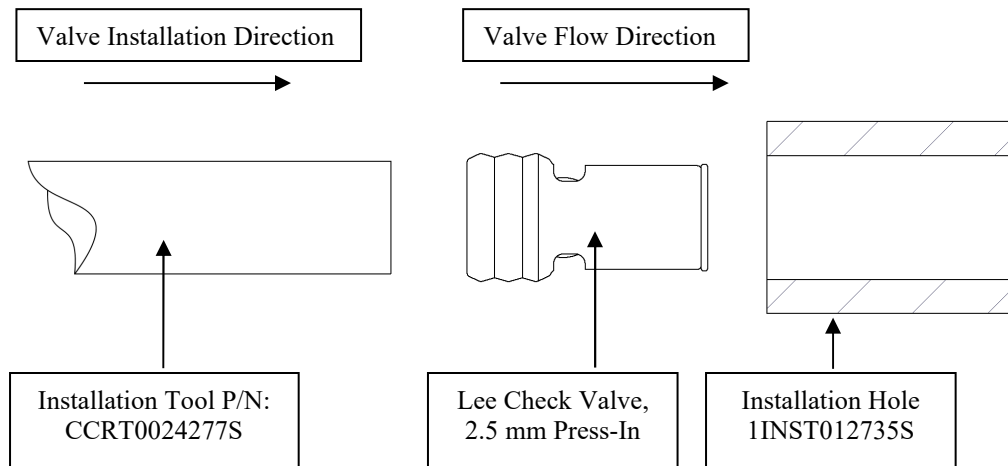

2. The installation tool (P/N: CCRT0024277S) is used to press the valve into a plastic installation hole until the valve is, at a minimum, flush with the top of the installation hole.

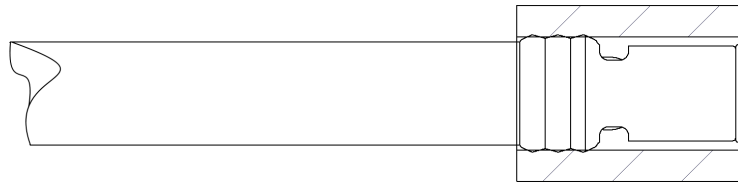

3. The series of smoothly curved lands of the Lee Check Valve, 2.5 mm, Press-In product seals and retains the product in the plastic installation hole.

Factory Best Practices:

1. Examine the condition of the Installation Tool at appropriate intervals and replace if damaged or chipped.
2. Clean feed bowls once per day.
3. Turn off vibratory feed bowl when the assembly station is idle, or if the feed rail is full of parts.
4. Use the minimum vibration setting to advance valves in the feed bowl.
5. If the check valve is blown into the assembly area from the feed rail, minimize the air pressure at which the check valve is blown into the assembly area to prevent possible damage.

4. Appendices

Appendix A Installation Hole

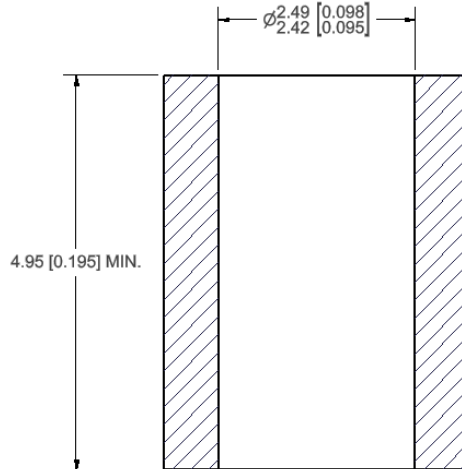

DIMENSIONS IN MILLIMETERS

Note: Draft angle to fall within diameter tolerance

Refer to Lee Drawing No. 1INST012735S

Appendix B Installation Tool

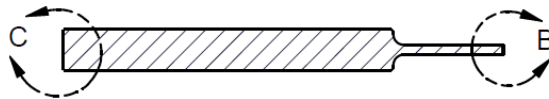
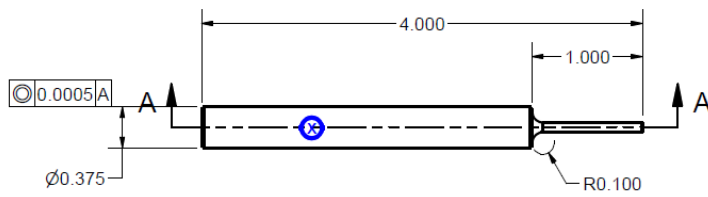

DETAIL B
SCALE 10 : 1

DIMENSIONS IN INCHES

Material: A2 Tool Steel

Hardness: 50-60 Rc

 Marked with part number and revision.

Refer to Lee Part No. CCRT0024277S