

PIEZOELECTRIC DISC  
PUMP (UxxB5xxxxxx)  
USER MANUAL





# PIEZOELECTRIC DISC PUMP (UxxB5xxxxxxx)

## USER MANUAL

1.	DISCLAIMER .....	3
2.	SPECIAL NOTICES .....	3
3.	INTRODUCTION .....	4
3.1.	Piezoelectric Disc Pump .....	4
4.	SAFETY .....	5
5.	PIEZOELECTRIC DISC PUMP OVERVIEW .....	6
6.	INSTALLATION .....	7
6.1.	Mechanical - Pump Mounting .....	7
6.2.	Pneumatic - Pump Manifolding .....	9
6.2.1.	Inlet filtration requirements .....	9
6.2.2.	BL/XP/LT Series pumps .....	9
6.2.3.	HP Series pumps .....	11
6.2.4.	US Series pumps .....	11
6.3.	Electrical - Pump “Flexi Tail” Connector .....	12
7.	SYSTEM OPERATION .....	13
8.	ACCESSORIES .....	14

8.1.	UACX0500850H Soft Y coupler (pack of 10).....	14
8.2.	UACX0500800H Silicone V coupler (pack of 10).....	15
8.3.	UACX0500750H (Filter) .....	15
9.	SUPPORT .....	16
10.	CERTIFICATE OF CONFORMITY & PRODUCT SAFETY / DECLARATION OF INCORPORATION .....	17
11.	REVISION HISTORY .....	20

## 1. DISCLAIMER

This resource is provided "as is" and without any warranty of any kind, and its use is at your own risk. The Lee Company does not warrant the performance or results that you may obtain by using this resource. The Lee Company makes no warranties regarding this resource, express or implied, including as to non-infringement, merchantability, or fitness for any particular purpose. To the maximum extent permitted by law The Lee Company disclaims liability for any loss or damage resulting from use of this resource, whether arising under contract, tort (including negligence), strict liability, or otherwise, and whether direct, consequential, indirect, or otherwise, even if The Lee Company has been advised of the possibility of such damages, or for any claim from any third party.

## 2. SPECIAL NOTICES

Throughout this User Manual, special notices relating to the safe and correct operation of the piezoelectric disc pumps are formatted and highlighted as follows:



### CAUTION

Instructions to ensure correct operation of the equipment and/or for avoiding damage to the equipment.

---



### WARNING

Instructions relating to the safety of the operator and avoiding injury.

---

### 3. INTRODUCTION

#### 3.1. Piezoelectric Disc Pump

The Lee Company's piezoelectric disc pumps are a multi-award winning technology which makes use of advances in the field of non-linear acoustics to offer the following unique features:

- silent operation
- ultra-smooth flow
- millisecond responsiveness
- compact form factor
- high-precision controllability

In contrast to conventional air pumping mechanisms (such as diaphragm and piston pumps), the disc pumps do not rely on the bulk compression of air within a cavity. Instead, the disc pumps generate a high amplitude, high frequency acoustic standing wave within a specially designed acoustic cavity. The operating frequency varies part-to-part and with pump operating conditions (e.g. temperature, pressure, etc). A dedicated drive circuit is therefore required to identify and track this frequency over time.

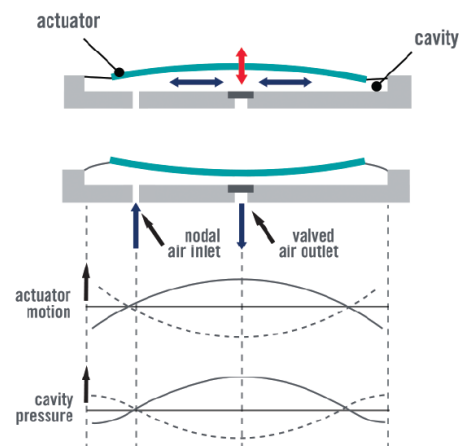

Figure 1. A schematic of the disc pump

Figure 1 shows a simplified schematic: the out-of-plane motion of the actuator drives in-plane (radial) motion of the gas in the cavity and creates a standing pressure wave, resulting in the oscillating cavity pressure shown. The motion of the actuator is highly exaggerated: there is virtually no net volume change of the cavity during operation, and at any given point in time there exists both a region of compression and a region of rarefaction within the cavity.

Rectification of the alternating cavity pressure is the key to delivering useful pump performance and device lifetime. The Lee Company has addressed this need by developing a family of innovative valve designs based on lightweight polymer valve flaps.

The disc pump technology is protected by a portfolio of both patent applications and granted patents.

## 4. SAFETY

### WARNING

The equipment described in this document is intended for use by skilled and competent personnel only. Further, the equipment is provided in a 'bare' format enabling users to integrate it into test fixtures, prototypes and product assemblies.

The user should satisfy themselves that the equipment is, and remains fit for, the intended use. The user accepts that The Lee Company shall not be held responsible or liable for any injury, damage or loss to property, person or otherwise, resulting from use of the equipment.

In order to aid assessment of the safety of the equipment, the following indicative electrical data are provided:



For typical disc pump driver circuits

**A.C. voltage on the PCB:** 120 V<sub>pp</sub> max. (at 20 – 22 kHz)

**D.C. voltage on the PCB:** 60 V max.

All disc pumps emit ultrasound in operation. The following data are provided for operation at maximum power (1.4W) at a distance of 30cm:

**Sound pressure level:** 70-80 dB SPL @ 30 cm typ. (at 20-22 kHz)<sup>1</sup>

1. Equivalent to <10 phon per ISO 226:2003 and related studies, 30 cm equivalent measurement distance

## WARNING



Take care during use of disc pump driver circuits not to create short circuits between exposed conductive parts of the PCBs. Short circuits may lead to malfunctioning and heating.

## 5. PIEZOELECTRIC DISC PUMP OVERVIEW

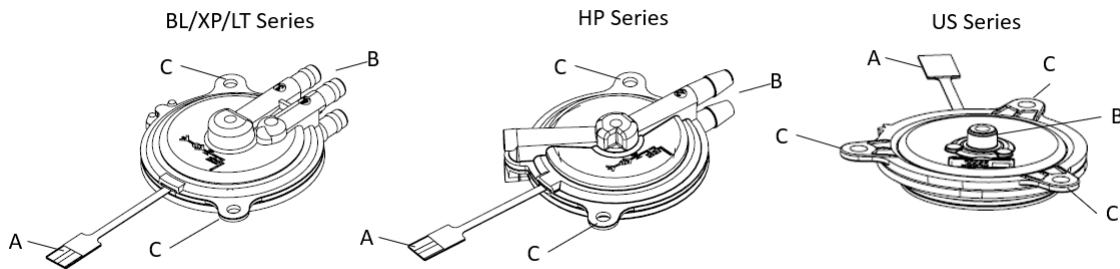

Figure 2. Piezoelectric pumps from the BL, XP, LT, HP and US Series, indicating A- Electrical, B- Pneumatic and C- Mechanical interfaces

The piezoelectric disc pump comes in a range of forms, with different mechanical and pneumatic installation requirements, as described in the following section. The table below provides a summary of the differences between the models.

Series	Mechanical Mounting	Pneumatic Connections	Electrical Connections
BL/XP/LT	2 off 2.2 mm diameter eyelets	4 off ~ 3.1 mm diameter barbs. Appropriate links between barbs required, depending on the product	4.5 mm wide electrical connector to fit 8 -way 0.5mm FPC Connector
HP		2 off ~ 3.7 mm diameter barbs. One inlet, one outlet	
US	3 off 2.2 mm diameter eyelets	X1 ~ 4 mm diameter connector intended for O-ring mounting.	

Table 1. The disc pump models

## 6. INSTALLATION

### 6.1. Mechanical - Pump Mounting

All pump series can be mounted via the 2.2 mm diameter eyelets provided. The pump should be mounted using a pair of O-rings (one above and one below, as shown below) and a nylon bolt to isolate the high frequency vibration of the pump and avoid audible noise.

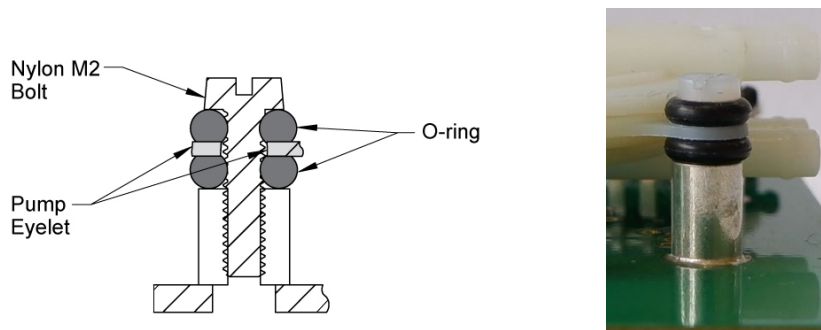

Figure 3. Example of mechanical pump mounting using two O-rings and a nylon bolt to prevent audible noise

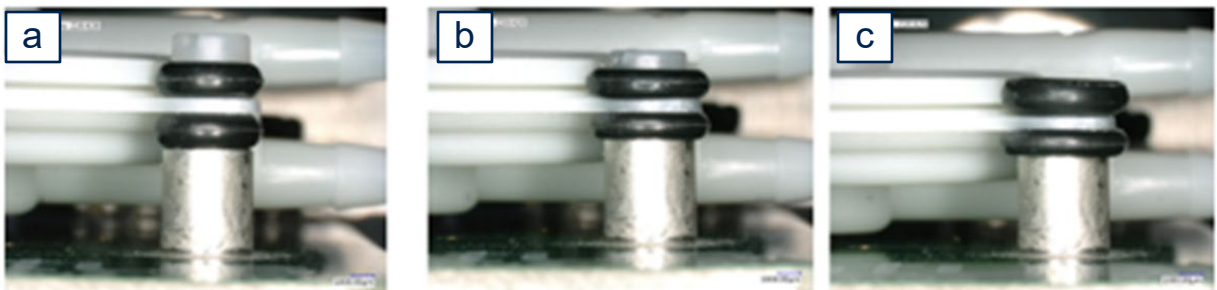

Figure 4. Images showing o-ring appearance as the nylon bolt is tightened. O-rings should be well compressed as shown in (b). Under tightening (a) or over tightening (c) may lead to audible noise.



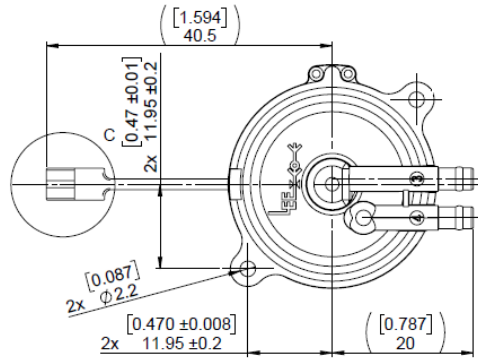

Figure 5. BL/XP/LT Series Mounting Geometry. Dimensions in mm [inches]

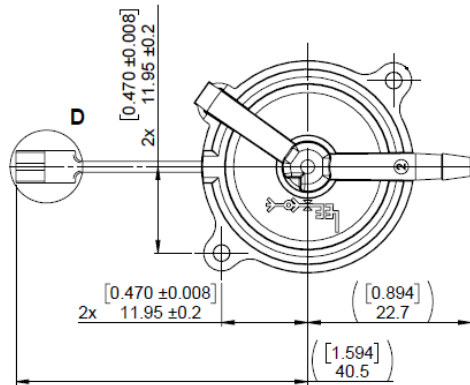

Figure 6. HP Series Mounting Geometry. Dimensions in mm [inches]

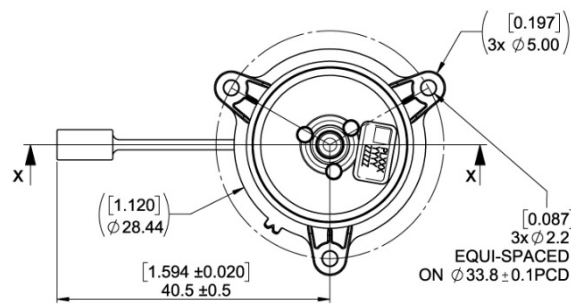

Figure 7. US Mounting Geometry. Dimensions in mm [inches]

## 6.2. Pneumatic - Pump Manifolding

### 6.2.1. Inlet filtration requirements

**TAKE NOTE**



All disc pumps should be operated with an inlet filter to prevent ingestion of debris that might otherwise shorten the operational life of the pump. The Lee Company recommends that a non-shedding filter with a pore size less than 3 microns is used.

### 6.2.2. BL/XP/LT Series pumps

For the BL, XP and LT pumps, which all have 4 pneumatic ports, it is important to connect the ports correctly depending on the pump configuration (series or parallel) to avoid poor performance and damage to the pump.

The configuration can be determined from the description of the product purchased or from the pump label, as shown below:

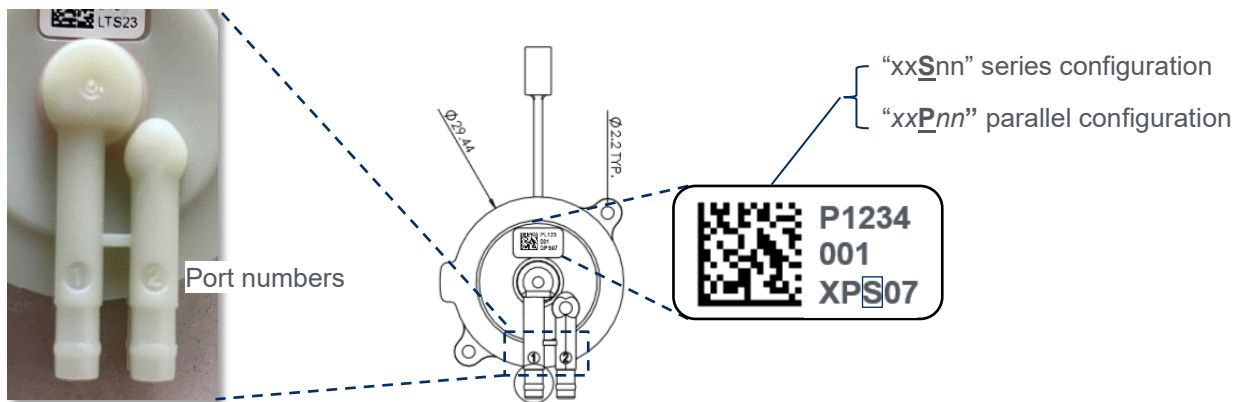

Figure 8. Identifying the pump configuration by the label and port numbering

## BL/XP/LT Series pumps - series configuration pumps

For series configuration pumps:

- Ports 2 and 4 must be linked (see the pump [Accessories](#) for suggested coupler)
- Port 3 is inlet
- Port 1 is discharge

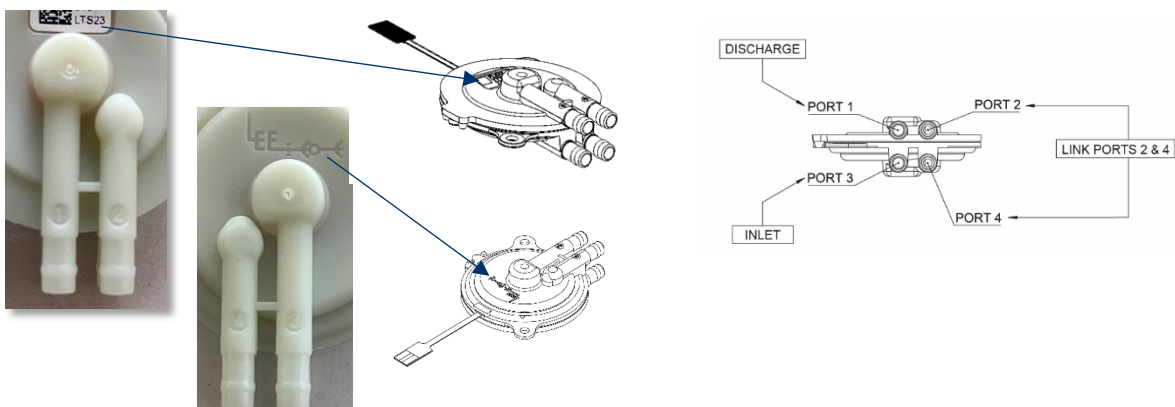

Figure 9. BL/XP/LT Series, series configuration pumps - port numbering displayed on ports

## BL/XP/LT Series pumps – parallel configuration pumps

For parallel configuration pumps:

- Ports 2 and 4 are the common inlet and should be linked\*
- Ports 1 and 3 are the common discharge and should be linked \*
- \* (see the pump [Accessories](#) for suggested coupler)

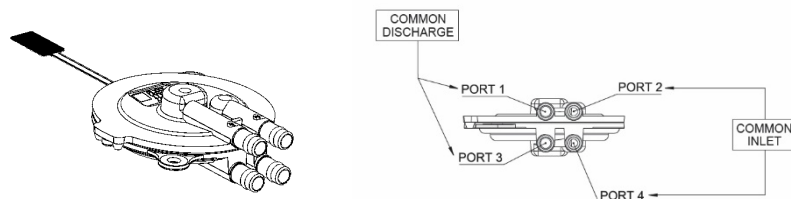

Figure 10. BL/XP/LT Series, parallel configuration pumps - port numbering

### 6.2.3. HP Series pumps

For HP Series pumps:

- Ports 2 is the inlet
- Ports 1 is the discharge

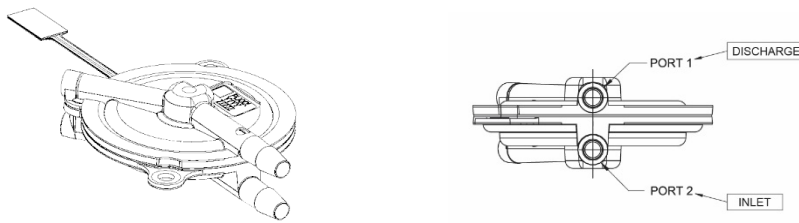

Figure 11. HP Series pumps - port numbering

### 6.2.4. US Series pumps

For US Series pumps:

- Port 1 is the outlet. This product is designed for axial seal on discharge port; product is not intended for direct connection to tubing. Please contact a Lee Sales Engineer for manifold mating boss guidance
- The intake cavity has a broad opening covered with an integrated flat filter. There is no porting arrangement, so this face is intended to be open to atmosphere as the inlet for the pump.

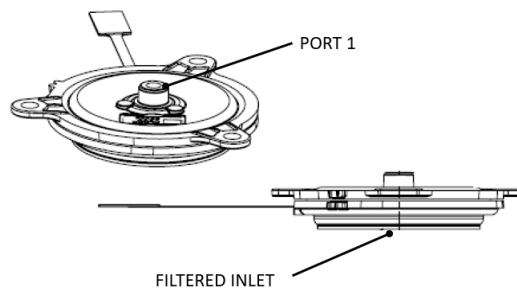

Figure 12. US Series pumps - port numbering

### 6.3. Electrical - Pump “Flexi Tail” Connector

The disc pump uses an FFC (flat flex connector) compatible with most 8-way 0.5mm pitch FFC connectors. The General Purpose Disc Pump Drive PCB has such a connector, and it is important that the disc pump.

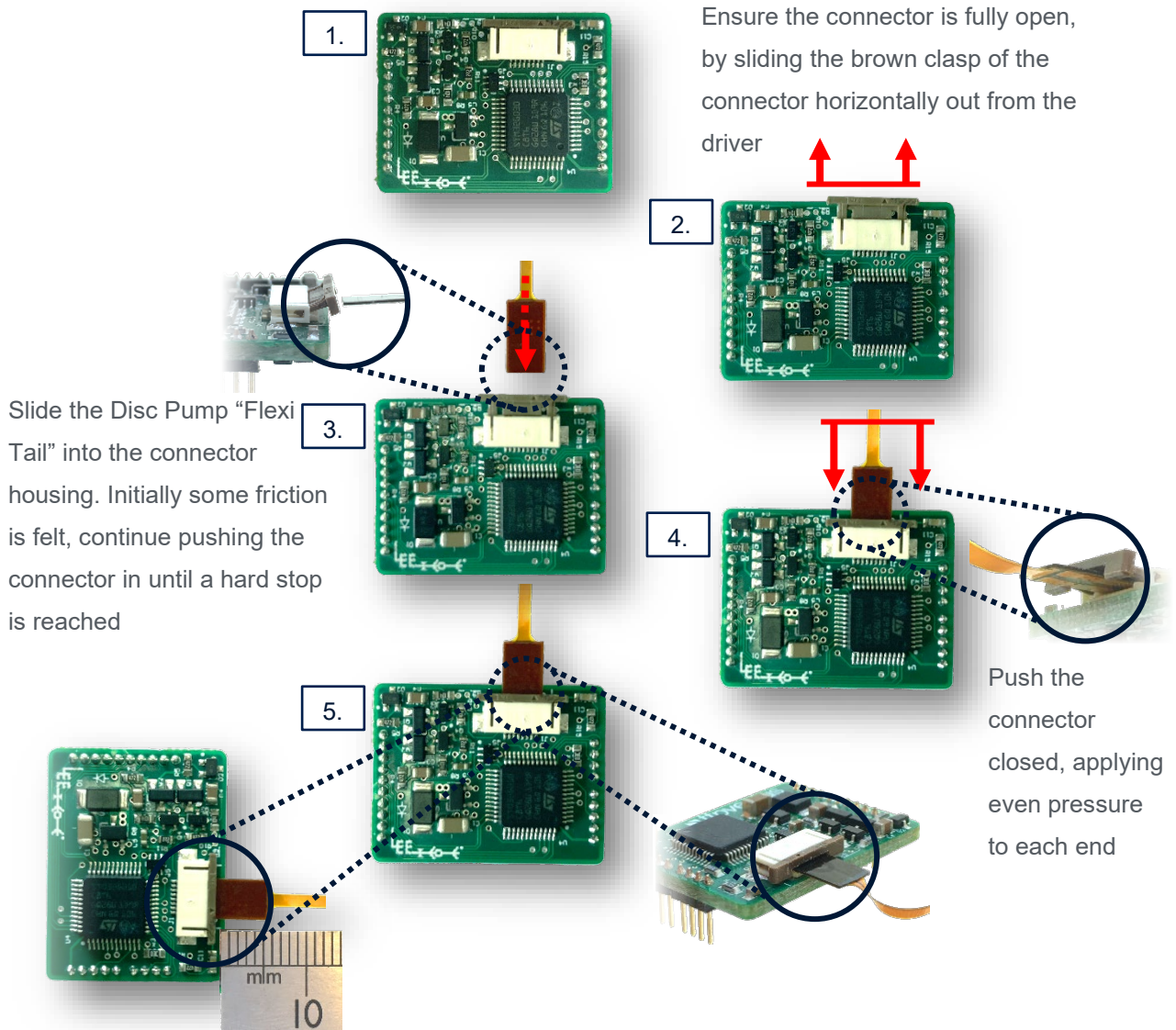

Figure 13. Connecting a pump to the Drive PCB

## 7. SYSTEM OPERATION

Once the disc pump has been installed correctly, it can be made to provide pneumatic output (pressure and/or flow) by applying a suitable a.c. drive signal to the pump electrical contacts. Details of this drive signal such as the waveform, frequency and voltage, must be continuously optimised to provide high pump efficiency.

Several suitable drive circuits are available from the Lee Company, and technical resources allowing engineers to integrate these circuits into their own products are available on request.

The maximum pneumatic output provided by a pump at a given drive power can be visualised by a load-line, as shown in Figure 14 below. The maximum pressure which can be generated (when there is no 'flow' requirement) is referred to as the Stall Pressure. The maximum flow rate which can be generated (when there is no pressure drop through the system) is referred to as the Free Flow. As the pump can be driven anywhere from 0 – 100% of the specified output, all flow and pressure combinations within the load-line envelope can be achieved.

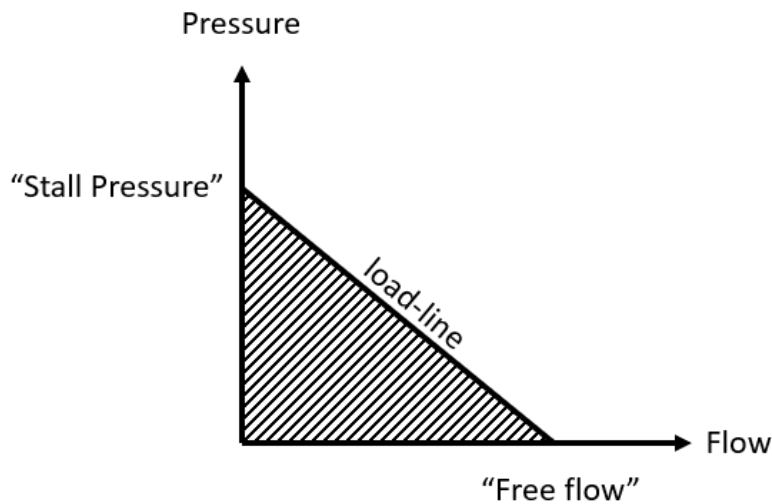

Figure 14: Typical pump load-line

## 8. ACCESSORIES

The following accessories are available for the Piezoelectric Disc Pump.

### 8.1.UACX0500850H Soft Y coupler (pack of 10)

The Soft Y-coupler provides a convenient method for linking ports in the parallel configuration pumps, as described in Section 6.2.

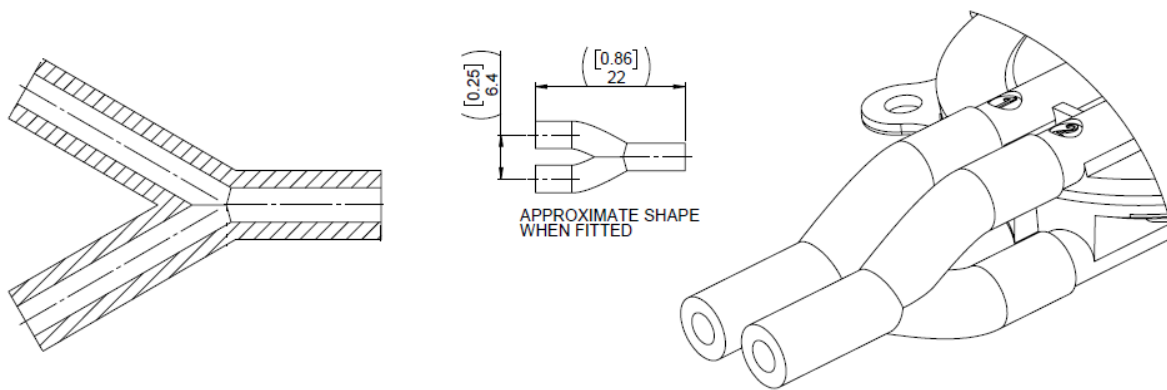

**Materials:** Silicone (60A)

**Notes:**

- Pneumatically links two pump ports (for BL, XP and LT Series Pumps with the parallel configuration) and presents a 2mm ID, 4mm OD tube for connection the customers system.
- Each pump may require two couplers.
- Product comes as a pack of x10 individual couplers.

## 8.2.UACX0500800H Silicone V coupler (pack of 10)

The Soft V-coupler provides a convenient method for linking ports in the series configuration pumps in systems, as described in Section 6.2.

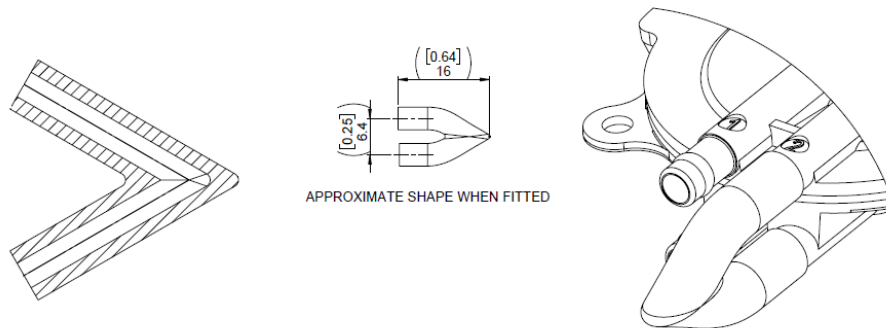

**Materials:** Silicone (60A)

**Notes:**

- Pneumatically links two pump ports (for BL, XP or LT Series Pumps with a series configuration)
- Product comes as a pack of x10 individual couplers

## 8.3.UACX0500750H (Filter)

It is recommended that the pump inlet is connected to a filter with a pore size of  $<3 \mu\text{m}$  to prevent ingress of debris which may reduce the performance of the pump.



Figure 15: Part UACX0500750H

**Materials:** Polypropylene Housing, Glass Microfibre membrane

**Notes:**

- 30 mm HPLC Syringe Filter
- Non-sterile
- Pore size of  $1.2 \mu\text{m}$





## 9. SUPPORT

The support section of The Lee Company website [www.theleeco.com/discpumps](http://www.theleeco.com/discpumps) provides technical information, FAQs, troubleshooting and documentation for download, including a range of application notes.

For additional technical support, including advice on testing of the products, please contact your Lee Sales Engineer.

## 10. CERTIFICATE OF CONFORMITY & PRODUCT SAFETY / DECLARATION OF INCORPORATION

	<p><b>LEE Ventus Limited</b> Melbourn Science Park Melbourn Hertfordshire SG8 6EE United Kingdom</p>
<p><u>EC and UKCA Declaration of Conformity</u></p>	
<p><b>Products:</b></p>	<p>Piezoelectric disc pumps and related modules, drive electronics and accessories</p>
<p><b>Models:</b></p>	<p>Piezoelectric disc pumps UBLB5xxxxxx (BL Series Disc Pumps) , UXPB5xxxxxx (XP Series Disc Pumps), UHPB5xxxxxx (HP Series Disc Pumps) , UUSB5xxxxxx (US Series Disc Pumps), ULTB5xxxxxx (LT Series Disc Pumps)</p> <p>Piezoelectric disc pump modules UxxC5xxxxxx (Smart Pump Modules incorporating any of the XP, BP, LT or HP Pump Series)</p> <p>Drive electronics and accessories UEKA0300000A (General Purpose Disc Pump Driver), UEKA0300050A (Evaluation Kit Motherboard), UEKA0300100A (Development Kit Motherboard), UACX0500100E (Breakout Board), UACX0500400E (SPM Communication Cable)</p>
<p>Serial numbers:</p>	<p>See label on product</p>
<p><b>Manufacturer:</b></p>	<p>LEE Ventus Ltd, Melbourn Science Park, Royston, Herts, SG8 6EE, UK</p>
<p><b>EU Authorised Representative:</b></p>	<p>The Lee Company Scandinavia AB, Stormbyvägen 2-4, 163 55 Spånga, Sweden</p>
<p>We hereby declare that the products above comply with all relevant provisions of the following directives:</p>	
<ul style="list-style-type: none"> <li>• Restriction of Hazardous Substances Directive 2011/65/EU</li> <li>• The Restriction of the Use of Certain Hazardous Substances in Electrical and Electronic Equipment Regulations 2012 No. 3032</li> </ul>	
<p>The products have been evaluated in accordance with the following harmonised standards:</p>	
<ul style="list-style-type: none"> <li>• EN IEC 63000:2018</li> </ul>	
<p>A technical file for each product is retained at the manufacturer's address.</p>	
<p>Signed</p>	
<p>Name:</p>	<p>Tom Harrison</p>
<p>Position:</p>	<p>Managing Director</p>
<p>P-2-056 Declaration of Conformity v03</p>	



LEE Ventus Limited  
Melbourn Science Park  
Melbourn  
Hertfordshire SG8 6EE  
United Kingdom

## Product Installation and Safety

<b>Products:</b>	<b>Pump drive PCBs and Accessories</b>
<b>Models:</b>	
Drive PCBs	UEKA0300000A (General Purpose Pump Drive PCB), UEKA0300050A (Evaluation Kit Motherboard), UEKA0300100A (Development Motherboard)
Accessories	UACX0500100E (General Purpose Pump Drive PCB Breakout Board), UACX0500400E (USB Power and Comms Cable) UACX0500950E (ACDC Adapter 5V dc Output, 5A Output with Plug Set)
<b>Manufacturer:</b>	LEE Ventus Ltd, Melbourn Science Park, Royston, Herts, SG8 6EE, United Kingdom

### General Product Safety Information:

- Products should only be used and mounted in accordance with the relevant User Manual.
- Do not disassemble products. If damage is evident, do not operate affected product.
- Do not operate products outside of their rated operating conditions. Operation outside these ratings may result in malfunction, excessive heating and/or noise emission.
- Electronic products may emit electromagnetic radiation. The customer should evaluate the emissions of the end product(s) to assess conformity with relevant limits.

### UEKA0300000A (General Purpose Drive PCB):

- The General Purpose Drive PCB can produce up to 60Vdc (120Vpp) under normal conditions, and >80Vdc (160Vpp) in a fault condition. Care must be taken when operating the General Purpose Drive PCB and in the design of products incorporating it to avoid exposure to electrical connections.
- Components on the board may become hot during use. This should be considered at the product design stage.
- The General Purpose Drive PCB emits electromagnetic radiation. The customer should evaluate the emissions of end product(s) incorporating the General Purpose Drive PCB to assess conformity with the relevant limits.
- Do not operate the General Purpose Drive PCB in an explosive atmosphere or where flammable materials are present.

### UACX0500950E (ACDC Adapter 5V dc Output, 5A Output with Plug Set)

- The power adaptor should be used in accordance with the supplier manual, which can be found on the supplier's website or on request from The Lee Company



## Declaration of Incorporation

**Products:** Piezoelectric disc pumps and related modules

**Models:**  
 Piezoelectric disc pumps UBLB5xxxxxxx (BL Series Disc Pumps), UXPB5xxxxxxx (XP Series Disc Pumps), UHPB5xxxxxxx (HP Series Disc Pumps), ULTB5xxxxxxx (LT Series Disc Pumps), UUSB5xxxxxxx (US Series Disc Pumps)  
 Piezoelectric disc pump modules UxxC5xxxxxxx (Smart Pump Modules incorporating any of the XP, BP, LT or HP Pump Series)

**Serial numbers:** See label on product

**Manufacturer:** LEE Ventus Ltd, Melbourn Science Park, Royston, Herts, SG8 6EE, UK

**EU Authorised Representative for CE Marking:** The Lee Company Scandinavia AB, Stormbyvägen 2-4, 163 55 Spånga, Sweden

- Installation and use:**
- Pumps and pump modules are classified as partly completed machinery intended for development of and integration into customer products by competent personnel.
  - Products should only be used in accordance with the relevant user manual.
  - The customer must ensure that voltages applied to the electrical connections are within the specified ratings.
  - The customer should ensure that the products are mounted in accordance with the relevant user manual and are not subject to forces which may distort the assembly.
  - The customer should ensure good electrical, mechanical, and pneumatic installation to prevent malfunction, leaks, noise generation, or the products becoming loose during operation.
  - Product performance may degrade over time. Customers must carry out adequate testing to ensure that the performance of the products in their particular application is sufficient to meet requirements over the life of the end products.

- Warnings:**
- Do not disassemble products. If damage is evident, do not operate affected product.
  - Do not operate products outside of their rated operating conditions. Operation outside these ratings may result in malfunction, or excessive heating or and/or noise emission.
  - Pumps operate at ultrasonic frequencies and can generate ultrasound levels up to around 80 dB SPL at 0.3m when operated at 1.4W input power. Care must be taken during testing and product design to comply with applicable ultrasound exposure limits.
  - Pumps and pump modules contain lead titanium zirconium oxide (CAS number 12626-81-2).
  - Pumps and pump modules contain piezoelectric elements which may store and/or generate electromechanical energy. Appropriate assessment must be carried out by the customer prior to use in explosive or flammable environments or for applications requiring Intrinsic Safety.
  - Pump modules can produce up to 60Vdc (120Vpp / 50 Vrms) under normal conditions, and >100 Vdc (200Vpp / 90 Vrms) in a fault condition. Care must be taken when operating pump modules and in the design of products incorporating them to avoid exposure to electrical connections.
  - The pump modules emit electromagnetic radiation. The customer should evaluate the emissions of the end product(s) to assess conformity with relevant limits.
  - Parts of the pump or pump module may become hot (>70 C) during normal operation, including certain electrical components. Customers must take appropriate care when handling pumps and pump modules and ensure that end users of products that incorporate these devices are protected when in operation.

**Declaration of Incorporation of partly completed machinery.**

According to The Machinery Directive (2006/42/EC) and Supply of Machinery (Safety) Regulations 2008 (S.I. 2012:3032) the products above are classified as partly completed machinery. These products are intended to be incorporated into or assembled with other items to form the final machinery.

It is the responsibility of the customer to ensure that the final machinery into which these products are incorporated have been declared in conformity with the relevant directives before being put into service.

A technical file for each product is retained at the manufacturer's address which has been compiled according to the Machinery Directive 2006/42/EC part B Annex VII. The technical file is available in electronic form on reasoned request by responsible authorities.

**Name:** Tom Harrison

**Position:** Managing Director

**Signed:**   
 Tom Harrison  
 cn=Tom Harrison, o=LEE Ventus,  
 email=harrison@theleeco.uk, c=GB  
 2024.03.19 10:27:44 Z

## 11. REVISION HISTORY

Revision	Date	Details
v04	6 <sup>th</sup> Feb 2025	Addition of Declaration of Incorporation and more detail on port numbers
v03	28 Oct 2024	Updated CE certificate, add Installation and Safety guidance and Declaration of Incorporation and pump port images.
v02	18 Dec 2023	Updated with new V and Y coupler accessories
v01	07 June 2023	Branding changes, inclusion of accessories and Certificate of Conformity
220513	13 May 2022	Initial release.