

# PIEZOELECTRIC DISC PUMP DEVELOPMENT KIT (UEKA0500300A)

## USER MANUAL

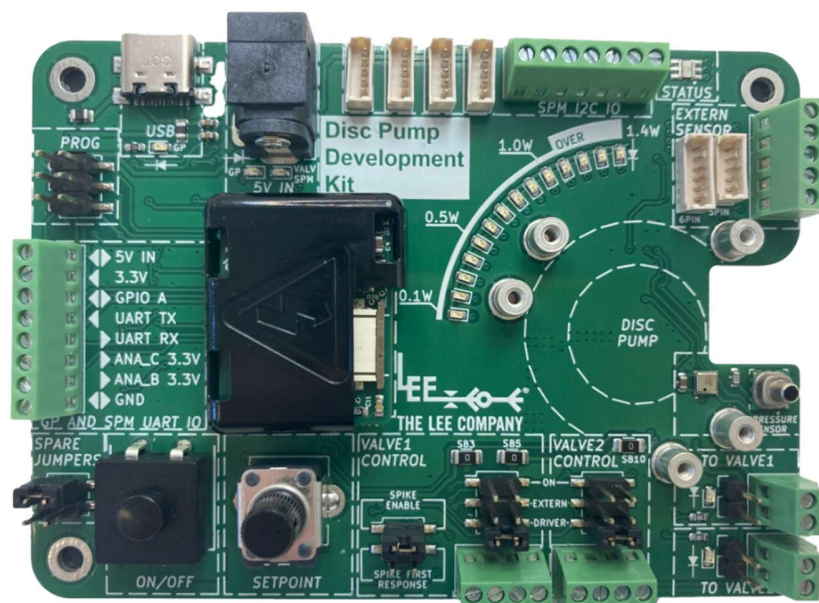



# PIEZOELECTRIC DISC PUMP DEVELOPMENT KIT (UEKA0500300A) USER MANUAL:

|       |   |    |
|-------|---|----|
| 1     | DISCLAIMER.....   | 4  |
| 2     | SPECIAL NOTICES.....                                      | 4  |
| 3     | INTRODUCTION .....  | 5  |
| 3.1   | Piezoelectric Disc Pump Development Kit .....             | 5  |
| 3.2   | Piezoelectric Disc Pumps .....                            | 5  |
| 4     | SYSTEM COMPONENTS .....                                   | 7  |
| 5     | SAFETY.....   | 8  |
| 5.1   | General Purpose Disc Pump Drive PCB protective cover..... | 9  |
| 6     | GETTING STARTED.....                                      | 11 |
| 6.1   | Set-up summary (installing a pump).....                   | 11 |
| 6.2   | Pump pneumatic connections.....                           | 11 |
| 6.2.1 | BL/XP/LT Series pumps.....                                | 11 |
| 6.2.2 | High Pressure (HP) Series pumps .....                     | 13 |
| 6.2.3 | UltraSlim (US) Series pumps .....                         | 13 |
| 6.2.4 | Filter .....  | 14 |
| 6.2.5 | Orifice .....   | 15 |
| 6.3   | Pump mounting guidance .....                              | 16 |
| 6.4   | Electrical connection.....                                | 17 |

- 6.5 Removing a pump..... 18
- 6.6 Power over USB and troubleshooting ..... 18
- 7 DEVELOPMENT KIT CAPABILITY OVERIEW ..... 20
- 8 DEVELOPMENT MOTHERBOARD DETAILED VIEW ..... 22
- 9 DETAILED SYSTEM OPERATION ..... 30
  - 9.1 Connecting a Smart Pump Module..... 30
    - 9.1.1 Connection cable..... 30
    - 9.1.2 Smart Pump Module via UART ..... 31
    - 9.1.3 Single Smart Pump Module via I2C ..... 32
    - 9.1.4 Configuration of multiple Smart Pump Modules via I2C ..... 33
  - 9.2 Controlling valves ..... 34
    - 9.2.1 Valve driving capabilities..... 34
    - 9.2.2 External controls and voltages ..... 37
    - 9.2.3 Valve troubleshooting..... 39
  - 9.3 External sensors / analog inputs ..... 40
    - 9.3.1 Digital flow sensors from Sensirion ..... 40
    - 9.3.2 Analog sensors or analog inputs..... 42
- 10 DISC PUMP CONTROL APP ..... 44
  - 10.1 Setup..... 44
  - 10.2 Getting started ..... 45
    - 10.2.1 Overview ..... 45
    - 10.2.2 Connecting a driver board..... 45
    - 10.2.3 System inputs..... 47
    - 10.2.4 System controls methods..... 47
    - 10.2.5 Power limit..... 53
    - 10.2.6 Measurement units..... 53
  - 10.3 Plotting ..... 54
    - 10.3.1 Plotting data from a single pump..... 54

|        |  |    |
|--------|--|----|
| 10.3.2 | Plotting data from multiple pumps.....                       | 56 |
| 10.4   | Valve control .....  | 57 |
| 10.5   | GPIO A.....  | 59 |
| 10.5.1 | Toggling the pump output with GPIOA.....                     | 59 |
| 10.5.2 | Configuring GPIO A as an output.....                         | 60 |
| 10.6   | Using the Analog Inputs.....                                 | 60 |
| 10.6.1 | Tracking pressure via the Analog Input.....                  | 60 |
| 10.7   | Multi pump control .....                                     | 64 |
| 10.8   | Logging .....  | 67 |
| 10.9   | Board settings menu.....                                     | 68 |
| 11     | ACCESSORIES.....   | 69 |
| 11.1   | Disc Pumps.....  | 69 |
| 11.2   | Mains power supply (UACX500950E).....                        | 70 |
| 11.3   | Smart Pump Module .....                                      | 70 |
| 11.4   | The Lee Company Valves .....                                 | 71 |
| 11.4.1 | HDI valves .....   | 71 |
| 11.4.2 | VHS valves.....  | 72 |
| 11.5   | Replacement parts.....                                       | 73 |
| 11.5.1 | Development motherboard (UEKA0300100A).....                  | 73 |
| 11.5.2 | General Purpose drive PCB (UEKA0300000A).....                | 73 |
| 11.5.3 | Pneumatic accessories .....                                  | 74 |
| 11.6   | Other off-the-shelf components .....                         | 74 |
| 11.6.1 | Smart Pump Module cable and Liquid flow sensors cables ..... | 74 |
| 11.6.2 | Pneumatic couplers and tubing.....                           | 74 |
| 12     | SUPPORT AND ADDITIONAL GUIDES.....                           | 75 |
| 13     | REVISION HISTORY .....                                       | 75 |

## 1 DISCLAIMER

This resource is provided "as is" and without any warranty of any kind, and its use is at your own risk. The Lee Company does not warrant the performance or results that you may obtain by using this resource. The Lee Company makes no warranties regarding this resource, express or implied, including as to non-infringement, merchantability, or fitness for any particular purpose. To the maximum extent permitted by law, The Lee Company disclaims liability for any loss or damage resulting from use of this resource, whether arising under contract, tort (including negligence), strict liability, or otherwise, and whether direct, consequential, indirect, or otherwise, even if The Lee Company has been advised of the possibility of such damages, or for any claim from any third party.

Use of the Development Kit, including all software and firmware provided with it, is subject to The Lee Company's standard terms and conditions of sale. The contents and packaging of the kit will vary depending on your individual orders.

## 2 SPECIAL NOTICES

Throughout this User Manual, special notices relating to the safe and correct operation of the Development Kit are formatted and highlighted as follows:



---

**CAUTION**

Instructions to ensure correct operation of the equipment and/or for avoiding damage to the equipment.

---

**WARNING**

Instructions relating to the safety of the operator and avoiding injury.

---

### 3 INTRODUCTION

#### 3.1 Piezoelectric Disc Pump Development Kit

The Piezoelectric Disc Pump Development Kit expands the use of disc pumps across a variety of applications through advanced functionality that includes multi-pump control, valve control & sensor compatibility, enabling the creation of advanced prototypes and speeding up development times.

---

**TAKE NOTE!**

The Development Kit itself does not include a pump, Smart Pump Module, valves or mains power supply. Pumps, modules and other accessories are ordered with The Development Kit as required.

---

This document provides details of the system. The disc pump is a gas pump, however it can be used to move liquids using pressure driven flow, using the appropriate equipment (please see our Application Notes for further examples).

#### 3.2 Piezoelectric Disc Pumps

The Lee Company's piezoelectric disc pumps are a multi-award winning technology which makes use of advances in the field of non-linear acoustics, to offer the following unique features for pumping gases:

- silent operation
- ultra-smooth flow
- millisecond responsiveness
- compact form factor
- high-precision controllability

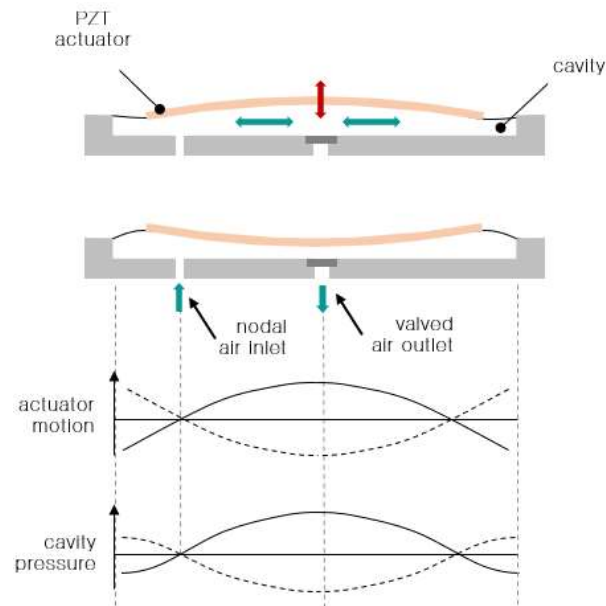

Figure 1 Principle of operation

In contrast to conventional air pumping mechanisms (such as diaphragm and piston pumps), our disc pumps do not rely on the bulk compression of air within a cavity. Instead, our micropumps generate a high amplitude, high frequency acoustic standing wave within a specially designed acoustic cavity.

Figure 1 shows a simplified schematic: the out-of-plane motion of the actuator drives in-plane (radial) motion of the gas in the cavity and creates a standing pressure wave, resulting in the oscillating cavity pressure shown. The motion of the actuator is highly exaggerated: there is virtually no net volume change of the cavity during operation and at any given point in time there exists both a region of compression and a region of rarefaction within the cavity.

Rectification of the alternating cavity pressure is the key to delivering useful pump performance and device lifetime. The Lee Company has addressed this need by developing a family of innovative valve designs based on lightweight polymer valve flaps.

Our disc pump technology is protected by a portfolio of both patent applications and granted patents.

**4 SYSTEM COMPONENTS**

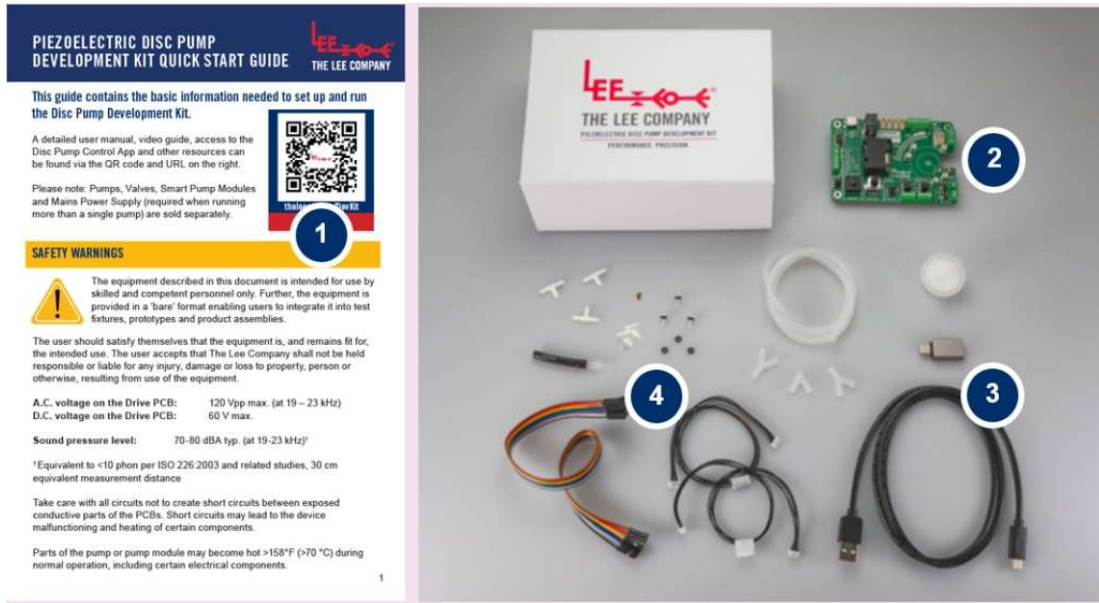

Figure 2 Piezoelectric Disc Pump Development Kit contents.

| Item | Description   |
|------|---|
| 1    | Quick start guide containing information on setting up the Development Kit and links useful resources such as the Disc pump control application.  |
| 2    | Development motherboard PCB, on which is mounted one postage-stamp sized pump General Purpose Drive PCB with a protective cap. This is packed within an ESD (electro-static discharge) bag. |
| 3    | USB cable and adapter, which enables the Disc Pump Control App to communicate with the drive PCB.   |
| 4    | Accessories kit including tubing, fittings, a Lee orifice, filter and cables.   |

Table 1. Component description

## 5 SAFETY



### WARNING

The equipment described in this document is research and development hardware intended for laboratory use by skilled and competent personnel only. Further, the components of this evaluation system have been provided in a 'bare' format enabling users to integrate the pump, drive electronics and power supply into test fixtures and prototype product assemblies.

The user should satisfy themselves that the equipment is and remains fit for the intended use. The user accepts that The Lee Company shall not be held responsible or liable for any injury, damage or loss to property, person or otherwise, resulting from use of the equipment.

To aid with safety assessment of the use of the equipment, the following indicative electrical data are provided:

**A.C. voltage on the Drive PCB:** 120 Vpp max. (at 19 – 23 kHz)  
**D.C. voltage on the Drive PCB:** 60 V max.

All Disc Pumps emit ultrasound in operation. The following data are provided for operation at maximum power (1.4W) at a distance of 30cm:

**Sound pressure level:** 70-80 dBA typ. (at 19-23 kHz)<sup>1</sup>

1. Equivalent to <10 phon per ISO 226:2003 and related studies, 30 cm equivalent measurement distance



### WARNING

Take care during use of the Development Kit not to create short circuits between exposed conductive parts of the PCBs. Short circuits may lead to malfunctioning and heating.



### WARNING

Components on the board may become hot during use, especially at elevated ambient temperatures.



To fit the protective cover:

- Hook the corner marked 'A' below so it clips over the board as shown in Figure 5, leaving the pump connector '4' accessible.
- Apply downwards pressure over the tabs marked 'B' and 'C', until the cover clicks into place.

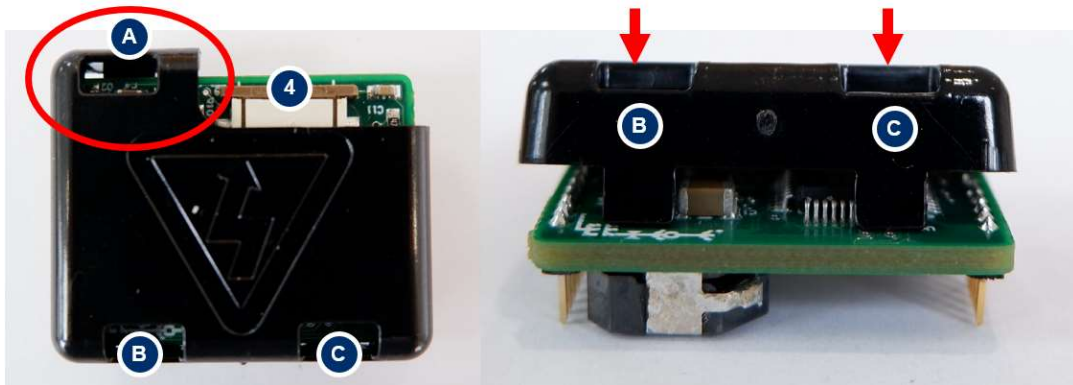

Figure 5. Fitting the protective cover to the General-Purpose Pump Drive PCB

To remove the protective cover:

- First remove the General Purpose Disc Pump Drive PCB and protective cover from the motherboard together by pulling vertically upwards.
- The protective cover can then be removed by gently pulling the clips 'B' and 'C' away from the PCB.

## 6 GETTING STARTED

### 6.1 Set-up summary (installing a pump)

- Remove motherboard from protective ESD bag.
- To run a disc pump, link pump ports and connect filter to inlet (see Section 6.2)
- Mount the pump on the motherboard (see Section 6.3) and connect to General Purpose Drive PCB (see Section 6.4)
- Connect the motherboard to PC with supplied USB cable.
- Use ON/OFF button and power dial to control pump.
- The Disc Pump Control App provides more complex control. To get started with the PC app/GUI, select the COM port from drop down list and click 'Connect'. If unsure of port, disconnect and reconnect the USB cable, noting which port disappears and reappears in drop down list.

### 6.2 Pump pneumatic connections

#### 6.2.1 BL/XP/LT Series pumps

- Take note of the pump configuration according to the pump labelling:

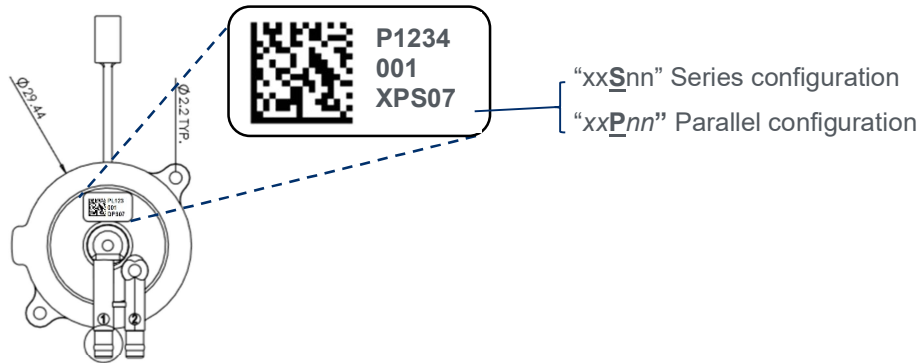

Figure 6 Pump labelling to distinguish between series and parallel pump configuration pumps

- Ensure the pump ports are connected according to the following diagram:

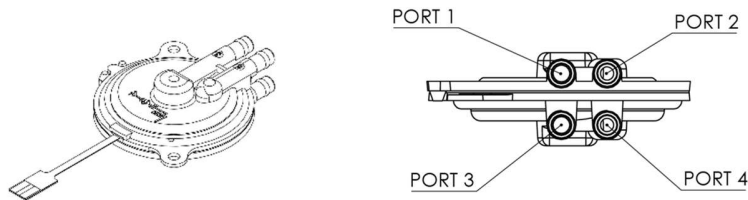

Figure 7 BL/XP/LT Series pumps - port numbering.

For series configuration pumps:

- Ports 2 and 4 must be linked – V coupler provided in the kit as shown in Figure 8.
- Port 3 is inlet.
- Port 1 is discharge.

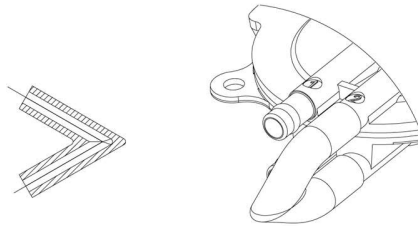

Figure 8 V coupler for Series configuration pump.

For parallel configuration pumps:

- Ports 2 and 4 are the common inlet and should be linked – Y coupler provided in the kit as shown in Figure 9.
- Ports 1 and 3 are the common discharge and should be linked – Y coupler provided in the kit as shown in Figure 9.

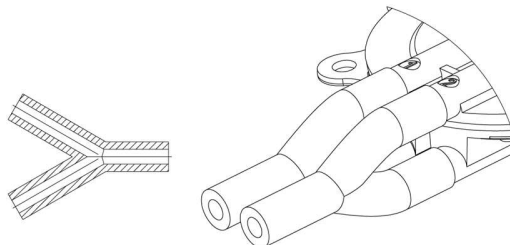

Figure 9 Y coupler for Parallel configuration pump.

### 6.2.2 High Pressure (HP) Series pumps

- Ports 1 is the inlet.
- Ports 2 is the discharge.

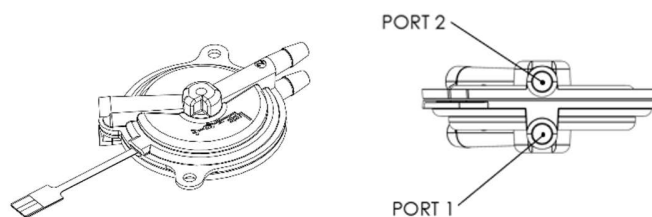

Figure 10 HP Series pump - port numbering.

### 6.2.3 UltraSlim (US) Series pumps

- Port 1 is the outlet – This product is designed for axial seal with a manifold block on the discharge port. While it is not intended for direct connection to tubing, it can be adapted to use standard tubing for evaluation with the US connector in the kit as shown in Figure 11.
- The inlet is filtered and not connectable.

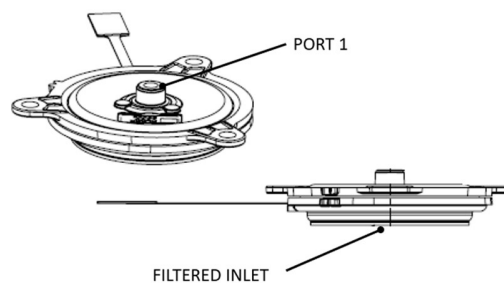

Figure 11. US Series pumps - port numbering

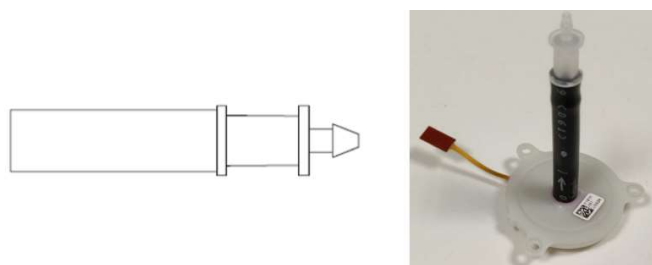

Figure 12 Connector for US Series pump evaluation

### 6.2.4 Filter



**TAKE NOTE!**

Ensure that a filter is connected to the pump inlet during operation.

The filter included in the kit should be always used when the pump is running. This ensures debris does not enter the inlet of the pump as that can lead to degraded performance and shortened lifetime. The filter can be adapted to the silicone tubing with the Luer connectors from the kit as shown in Figure 13.

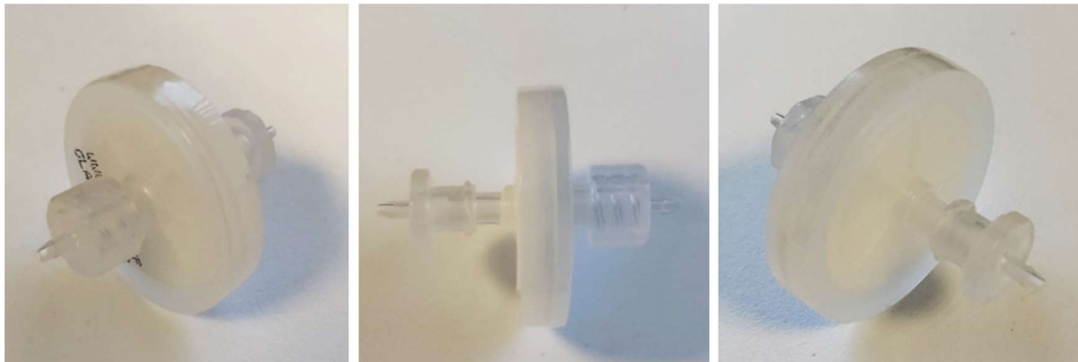

Figure 13 Filter with installed Luer connectors on both sides.

A typical connection of the filter with the disc pump is shown in Figure 14.

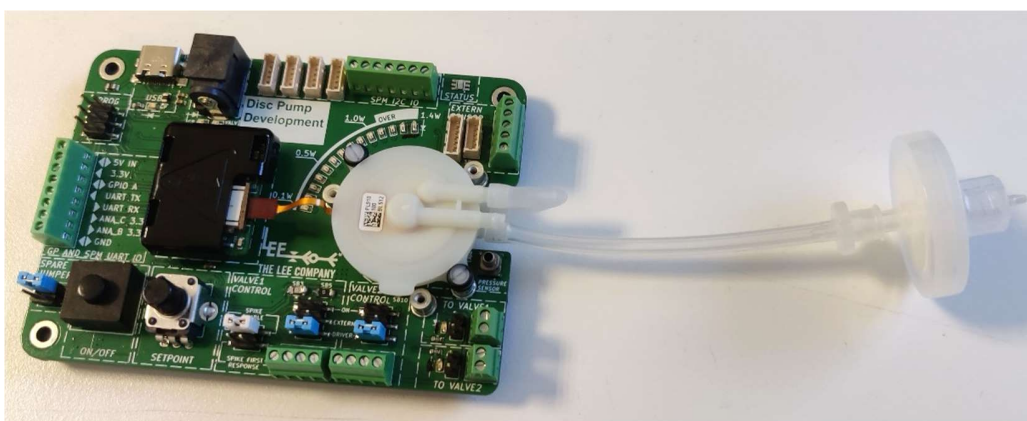

Figure 14 Disc Pump connected with inlet filter.

### 6.2.5 Orifice

The orifice allows the pressure in the discharge line (or system) to decay more quickly when the pump is not running. This setup (as seen in Figure 16) will make tracking a pressure point with PID control more precise and quicker to converge. However, using a bleed orifice will reduce the maximum pressure capability or increase the input power needed to achieve a working point so the benefits need to be weighed up.

The orifice can be pushed into a piece of tubing as shown in Figure 15. Note that the orifice is bidirectional. The orifice included in the kit has a flow resistance of 30K Lohm, and alternative orifices for faster or slower pressure decay are available from The Lee Company.



Figure 15 Orifice (left) and orifice installed in a tube (right).

A typical setup using the orifice to bleed pressure from the system is shown in Figure 16.

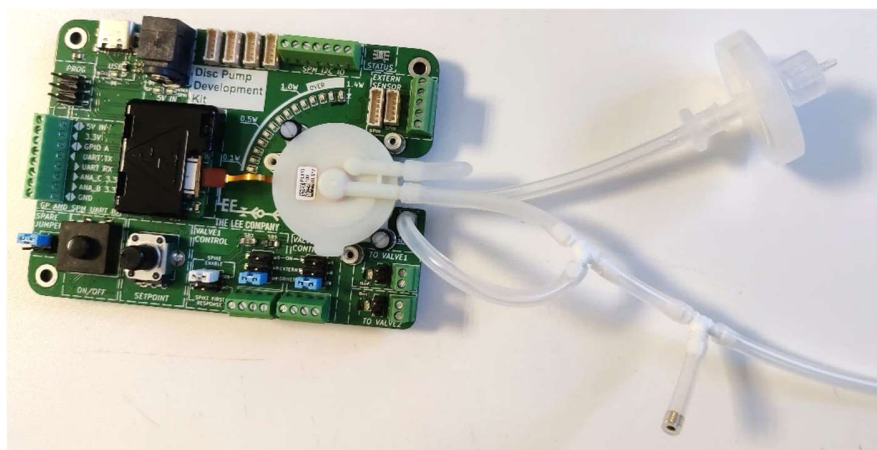

Figure 16 Disc Pump output connected to the on-board pressure sensor and using a bleed orifice. The target system should be connected to the tube going off picture to the right.

### 6.3 Pump mounting guidance

The Development Kit itself does not include a pump or Smart Pump Module. Pumps, modules and other accessories can be ordered as additional line items as required when ordering the Development Kit. Depending on the pump model, each pump has either two or three mounting eyelets. When installing pumps, make sure that two O-rings are used per mounting eye (one above and one below the eye), and use the supplied Nylon M2 bolts. This mounting scheme isolates high-frequency vibration and prevents audible noise. Note that metal bolts are not recommended for this reason.

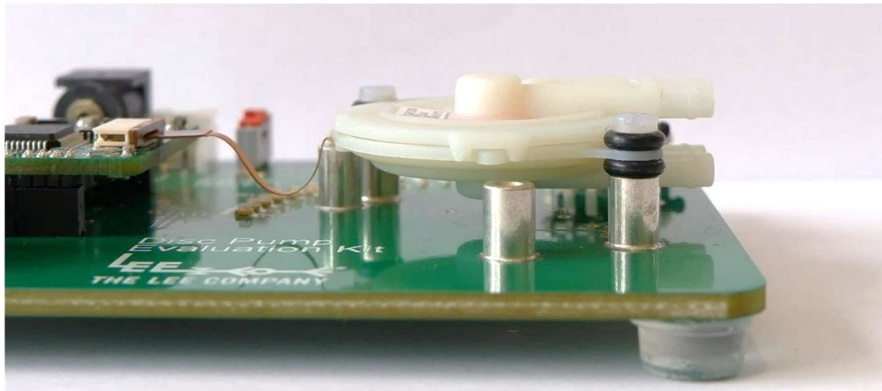

Figure 17. Example of recommend pump mounting



Figure 18. Images showing O-ring appearance as the nylon bolt is tightened. O-rings should be well compressed as shown in (b). Under tightening (a) or over tightening (c) may lead to audible noise

---

**TAKE NOTE!**



Failure to mount the pump correctly can result excessive movement of the FFC (flat flex connector) (power cable) in the FFC connector. This can result in a short circuit and permanent damage.

---

### 6.4 Electrical connection

The disc pumps use an FFC (flat flex connector) compatible with most 8-way 0.5mm pitch FFC connectors. The Disc Pump Driver PCB has such a connector, and it is important that the disc pump “Flexi Tail” is properly seated in this connector, see Figure 19 below. Once the pump is mounted and the system powered, the Disc Pump Control app can be used to control the pump as outlined in Section 10.

**1.** Ensure the connector is fully open, by sliding the brown clasp of the connector horizontally out from the driver.

**2.** Push the connector closed, applying even pressure to each end.

**3.** Slide the Disc Pump “Flexi Tail” into the connector housing. Initially some friction is felt, continue pushing the connector in until a hard stop is reached.

**4.** Push the connector closed, applying even pressure to each end.

**5.** Visually inspect the connection, ~5mm should be exposed which would verify that the “Flexi Tail” is properly seated into the connector.

Figure 19 FFC connecting and reverse for removal

## 6.5 Removing a pump

### CAUTION



Whether removing or installing a pump, always power down the Development Kit first by removing the mains power supply and USB cable. Failure to do so may result in damage to the system.

- Power down the system and remove the USB cable / Power supply cable.
- Pull out the brown clasp evenly on the FFC connector (reverse of Figure 19) so that it is in the open position.
- Remove the pump flexi-tail from the FFC connector (reverse of Figure 19).
- Unscrew the pump mounting screws (Figure 17).
- Retain the O-rings used to mount the pump for later use.

## 6.6 Power over USB and troubleshooting

The Development Kit can be powered using the USB cable provided, when one pump or Smart Pump Module are controlled via UART. Once the pump is mounted and the system powered, the Disc Pump Control app can be used to control the pump as outlined in Section 10.

Most USB ports are capable of supplying sufficient current of at least 500mA, however this is not always the case. Some older USB ports or crowded USB hubs are only capable of supplying 100mA which is not enough to power the Development Kit.

In the event of connecting the Development Kit to a USB port that is not capable of supplying sufficient current, the following error message will appear on screen (see Figure 20). The error means the USB port has been turned off to prevent damage to the computer. To fix the problem disconnect the Development Kit and dismiss the error message by clicking “Reset”. Connect the Development Kit to a wall power adapter and once the Kit has powered on, connect it to the computer via USB.



Figure 20. Error when connecting the Development Kit to a low power USB port

To disable powering through USB:

- Power down the system and remove all cables.
- Desolder the 0 Ohm resistor labelled "SB1" on the underside of the motherboard, as shown in Figure 21.

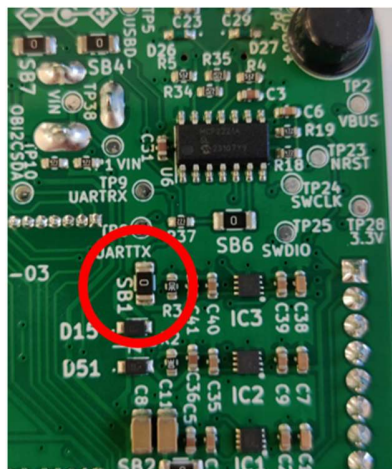
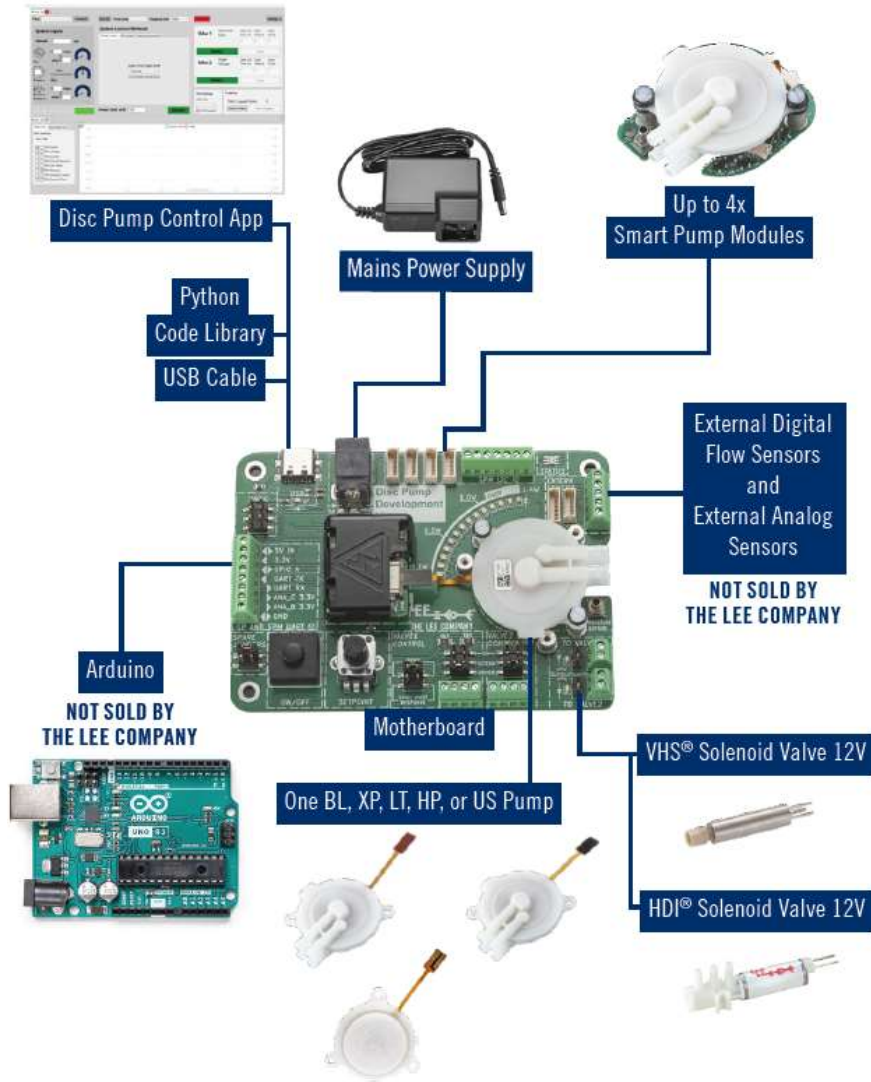

Figure 21 Remove "SB1" to disable power over USB

**7 DEVELOPMENT KIT CAPABILITY OVERVIEW**



**Please contact The Lee Company to purchase components sold separately**

Figure 22 Development kit capability overview

| Capability   | User manual sections                        | External resources   |
|--|---|--|
| Driving a GP driver and Disc Pump                          | Section 6<br>Section 10.2                   | Disc Pump Drive PCB User Manual<br>Piezoelectric Disc Pump User Manual   |
| Driving one or multiple Smart Pump Modules                 | Section 9.1<br>Section 10.2<br>Section 10.7 | Smart Pump Module User Manual<br>Piezoelectric Disc Pump User Manual   |
| Controlling valves   | Section 9.2<br>Section 10.4                 | AN049: Pipetting Application Note: Piezoelectric Disc Pumps<br>AN069: Time-metered dosing: Piezoelectric Disc Pumps  |
| Disc Pump Control App                                      | Section 10                                  |  |
| External flow sensors and other sensors                    | Section 9.3<br>Section 10.6                 | AN002: Microfluidics Application Note: Piezoelectric Disc Pumps<br>AN007: Microfluidics Driver Application Note: Piezoelectric Disc Pumps                        |
| External control using Arduino or other microcontrollers   | Section 8                                   | TG003: PCB Serial Communications Guide<br>GitHub Code Snippet Library<br>( <a href="https://github.com/The-Lee-Company">https://github.com/The-Lee-Company</a> ) |
| External control using Python or other scripting languages | Not covered in this user manual             | TG003: PCB Serial Communications Guide<br>GitHub Code Snippet Library<br>( <a href="https://github.com/The-Lee-Company">https://github.com/The-Lee-Company</a> ) |
| Other applications   | Not covered in this user manual             | See Section 12 for more guides and application notes.  |

Table 2: Development Kit Functionality

Note that no Disc Pumps, modules, valves or mains power supply are included in the Development kit.

Note that the mains power supply is required to drive valves or more than one Disc Pump or Smart Pump Module.

For more information, please see Section 11 or contact the local Lee sales representative.

## 8 DEVELOPMENT MOTHERBOARD DETAILED VIEW

The piezoelectric disc pump must be driven with an AC drive signal at a frequency optimised to suit each pump and its operating conditions. The General Purpose Disc Pump Drive PCB is responsible for generating the necessary drive signal. The pump and Drive PCB are mounted onto a motherboard as shown in Figure 23. The motherboard provides a range of convenient and easy-to-use connections, user interface elements and functionality, as detailed in Table 2.

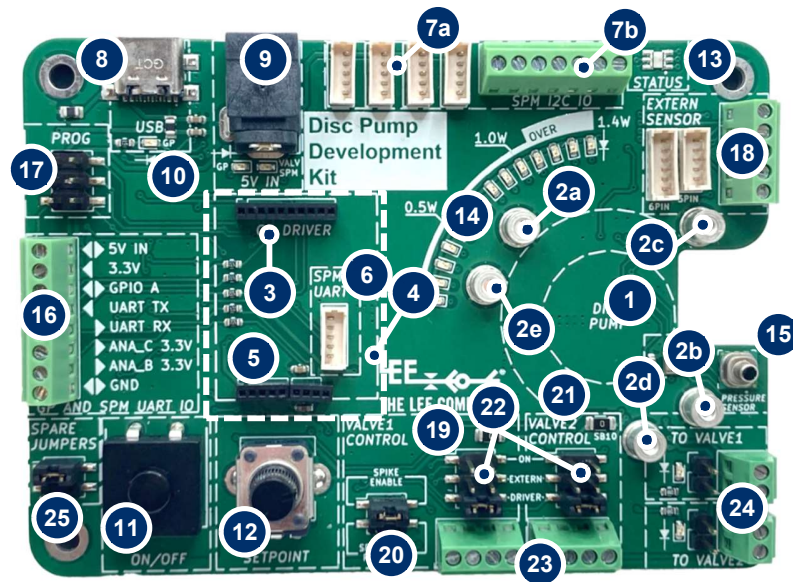
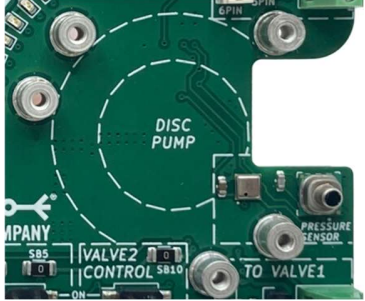
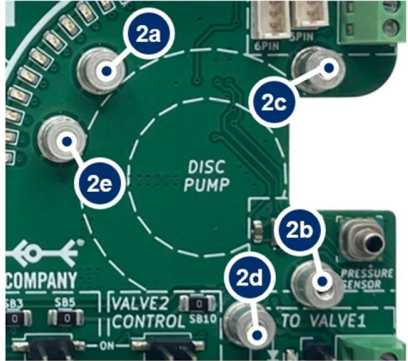













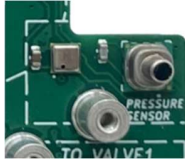

Figure 23. Development Kit Motherboard



| Item       | Details  | Picture  |
|------------|--|--|
| 1          | <p>Mounting location for The Lee Company Disc Pump (US series pumps have three mounting lugs, while other models have two).</p>  |    |
| 2a/b/c/d/e | <p>Pump mounting stand-offs – two port pumps (e.g. BL, XP and HP series) mount on 2a and 2b, and three port pumps (e.g. US series) mount on 2c, 2d and 2e. Note that whilst disc pump operates ultrasonically and is therefore inaudible, it is possible for the pump to vibrate against the mounting features or casework. To prevent this vibration causing audible noise, the pump is mounted with compliant O-rings and nylon bolts as shown in Section 6.3.</p> |   |
| 3          | <p>General Purpose Disc Pump Drive PCB.</p>  |  |

|              |  |  |
|--------------|--|--|
| <p>4</p>     | <p>Flat flex connector (FFC) connector: electrical connection between pump and PCB (see Section 6.4).</p>  |    |
| <p>5</p>     | <p>High voltage protective cap. This cap should be installed at all times when the board is powered on.</p>  |    |
| <p>6</p>     | <p>SPM UART - Smart Pump Module connection via UART.<br/><br/>Note that either the General Purpose driver or the Smart Pump Module via UART can be connected at any one time due to the UART protocol only supporting communication with a single device.</p>  |   |
| <p>7 a/b</p> | <p>SPM I2C IO – Four Smart Pump Module connections 7a via I2C. Note that driving Smart Pump Modules over I2C requires the external mains power supply. For setting up multiple Smart Pump Modules to work simultaneously over I2C see Section 9.1.4</p> <p>The screw terminal 7b provides external control signals to the Smart Pump Module via I2C (connections indicated on the back of the board):</p> <ul style="list-style-type: none"> <li>• I2C SLC/SDA – 3.3V-level serial data transmitted from / received by the Smart Pump Module connected. The development system can be controlled by the customer’s host PCB (e.g. a microcontroller).</li> <li>• SPM_ANALOG_1/2/3/4 – 0 to 3.3V analog input. The Smart Pump Modules can be configured to be controlled by this signal in the PC application.</li> </ul> |  |

|          |  |  |
|----------|--|--|
|          | <ul style="list-style-type: none"> <li>GND – Ground connection, required for connecting the customer’s host PCB (e.g. a microcontroller).</li> </ul>   |  |
| 8        | <p>USB IN – connect at PC to the PCB with the supplied USB cable to allow the Disc Pump Control App (see Section 10) to communicate with the General Purpose driver or a Smart Pump Module connected via UART. The USB IN allows powering and using the system without the need for the mains power adapter.</p> <p>Note that the USB port providing power must be capable of supplying 500 mA or greater.</p> <p>Note that the USB port is only able to power the General Purpose driver or a Smart Pump Module connected via UART. For powering Smart Pump Modules over I2C or the Valve drivers, the mains power adapter is required.</p> |    |
| 9        | <p>5V IN – connection for the mains transformer to power the system. This powers the whole system including the General Purpose drive, Smart Pump Module connected via UART or I2C and the Valve drivers.</p> <p>Note that the 5V IN port must be capable of supplying 5 A or greater.</p>   |  |
| 10 a/b/c | <p>Power indicator LEDs. These LEDs indicate that the system is receiving power from the corresponding power source:</p> <ul style="list-style-type: none"> <li>10a - USB port is powering the General Purpose driver or a Smart Pump Module connected via UART.</li> <li>10b - The 5V IN port is powering the General Purpose driver or a Smart Pump Module connected via UART.</li> <li>10c - The 5V IN port is powering the Smart Pump Modules connected via I2C and the Valve drivers.</li> </ul>  |  |

|                  |   |  |
|------------------|---|--|
| <p><b>11</b></p> | <p>ON/OFF – pump on/off switch. A single click will toggle the pump on/off. The pump may also be turned on/off by the PC application.</p>   |    |
| <p><b>12</b></p> | <p>SETPOINT – rotary control allowing the system setpoint to be adjusted. By default, this adjusts the drive power supplied to the pump, although it can be configured to control other parameters via the PC application.</p>  |    |
| <p><b>13</b></p> | <p>STATUS LED – indicates the state of the pump:</p> <ul style="list-style-type: none"> <li>• Pump idle – breathing green* colour.</li> <li>• Pump on – solid green* colour.</li> <li>• Error – blinking red and green* colour.</li> </ul> <p>*The default green colour of the Status LED is adjustable via the PC application. This can be helpful when running multiple pumps to give a visual indication of which tab of the PC application corresponds to which pump.</p> <p>Errors can be cleared by toggling the pump off and on again, or by power cycling the system.</p> <p>If the error persists, check the contact with the flexi tail (FFC) and the drive PCB. If contact appears satisfactory but the error light stays on, try installing another pump.</p> <p>If the error disappears, contact with the original pump may not have been satisfactory or the original pump may be faulty.</p> |  |

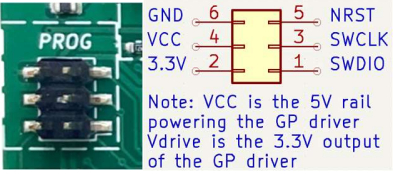
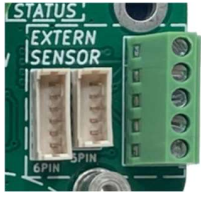
|           |   |  |
|-----------|---|--|
| <p>14</p> | <p>Power gauge: array of LEDs to indicate the drive power being supplied to the pump. For continuous operation, The Lee Company recommends that drive power is limited to 1 W. For intermittent use, a maximum limit of 1.4 W may be feasible depending on the duty cycle.</p>  |    |
| <p>15</p> | <p>PRESSURE SENSOR - Differential pressure sensor: when connected to the pneumatic circuit, allows the pressure generated by the pump to be measured and displayed in the PC application. The sensor is capable of measuring positive and negative pressures up to <math>\pm 920</math> mbar (<math>\pm 13.5</math> psi). The development system is capable of PID/closed-loop control of the pump pressure.</p>  |   |
| <p>16</p> | <p>GP AND SPM UART IO – External signal connections: screw terminal block providing the following connections:</p> <ul style="list-style-type: none"> <li>• 5V IN – wired to the 5V IN connector 9. Can be used to power the system or to output power to a microcontroller. Ensure that any connected power supply is capable of delivering sufficient power to / from the system. <u>This pin is not protected against overvoltage.</u></li> <li>• 3.3V – output from GP drive PCB that can be used to power 3.3V devices (max 50 mA).</li> <li>• GPIOA – 3.3V-level digital toggle signal IO for enabling / disabling pumping with an external signal. This pin can also be configured as an output via the PC application.</li> <li>• UART T/RX – 3.3V-level serial data transmitted from / received by the General Purpose driver or the Smart Pump Module connected via UART. The development system can be controlled by the customer’s host PCB (e.g. a microcontroller)/system via these connections.</li> </ul> |  |

|    |  |  |
|----|--|--|
|    | <ul style="list-style-type: none"> <li>ANALOG_C/B – 0 to 3.3V analog input. The development kit can be configured to be controlled by this signal in the PC application.</li> <li>GND – Ground connection, required for connecting the customer's host PCB (e.g. a microcontroller).</li> </ul>  |  |
| 17 | <p>PROG – programming header that can be used to program the General Purpose Driver. Contact the local Lee representative for more information on programming the General Purpose Driver.</p>  |    |
| 18 | <p>EXTERN SENSOR – The development kit supports a range of external sensors through the External Sensor connector headers (see Section 9.3). This header also has stable low noise 3.3V and 5V rails for powering digital and analog sensors (100mA max).</p>  |   |
| 19 | <p>VALVE 1 CONTROL – Valve driver enabling the General Purpose driver to control a Lee Co. High Speed VHS valve, Lee Co. HDI Valve or any other 12V valve.</p> <p>Note the maximum power the system is capable of outputting is 2W at 12V.</p> <p>Note that driving valves requires the external mains power supply.</p>   |  |
| 20 | <p>VALVE 1 CONTROL – Selecting the type of valve.</p> <ul style="list-style-type: none"> <li>To set the valve driver to drive a Lee Co. High Speed VHS valve SET the SPIKE ENABLE jumper.</li> <li>To set the valve driver to drive a Lee Co. HDI Valves or any 12V valve REMOVE the SPIKE ENABLE jumper.</li> <li>For more information on the spike and hold properties or the SPIKE FIRST RESPONSE see Section 9.2.</li> </ul> |  |





|                  |   |  |
|------------------|---|--|
| <p><b>21</b></p> | <p>VALVE 2 CONTROL – Valve driver enabling the General Purpose driver to control a Lee Co. HDI Valve or any other 12V valve.</p> <p>Note the maximum power the system is capable of outputting is 2W at 12V.</p> <p>Note that driving valves requires the external mains power supply.</p>  |    |
| <p><b>22</b></p> | <p>Both valve drivers can be controlled by multiple sources:</p> <ul style="list-style-type: none"> <li>Manually turning the valve on by setting the ON position.</li> <li>Valve controlled by the General Purpose drive board by setting the DRIVER position (default).</li> <li>Valve controlled by an external control signal on the screw terminal by setting the EXTERN position.</li> </ul> |   |
| <p><b>23</b></p> | <p>Both valve drivers can be configured to work with different voltage valves by using an external power supply. For more information on external connections see Section 9.2.2 (Note this requires soldering)</p>  |  |
| <p><b>24</b></p> | <p>TO VALVE 1/2 – Output headers to the two valves. The outputs are equipped with an LED indicating the output state to the valve.</p>  |  |
| <p><b>25</b></p> | <p>SPARE JUMPERS – A place to keep spare jumpers to avoid losing them.</p>  |  |

Table 2. Development motherboard details

## 9 DETAILED SYSTEM OPERATION

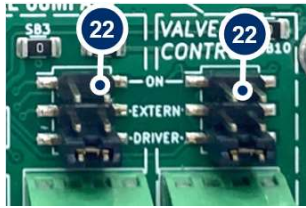
### 9.1 Connecting a Smart Pump Module

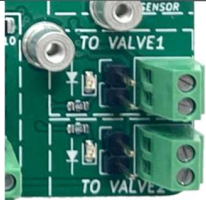
The Smart Pump Module can be connected to the Development Kit motherboard via UART (serial) or I2C. By default, the Smart Pump Module autodetects the communications protocol so it could be connected to both. Both connections allow the full functionality of the module and can be used with third party automation such as Python, but there are a few key differences:

- UART requires only USB power while I2C requires the mains power supply.
- UART can use the setpoint dial to control pump power.
- I2C can connect to multiple Smart Pump Modules at once with a single communications line (e.g. a single USB cable). Note that using multiple modules requires an additional setup step explained below.



Figure 24 Smart Pump Module equipped with an XP series pump.

#### 9.1.1 Connection cable

The Smart Pump Module requires a Molex Picoblade 5pin female-female cable, which is included in the kit. Off the shelf cables can be found on online electronics retailers such as Mouser or RS Components.



Figure 25 SPM connection cable

### 9.1.2 Smart Pump Module via UART

Remove the General Purpose driver from the Development kit motherboard and connect the Smart Pump Module to the SPM UART connector.

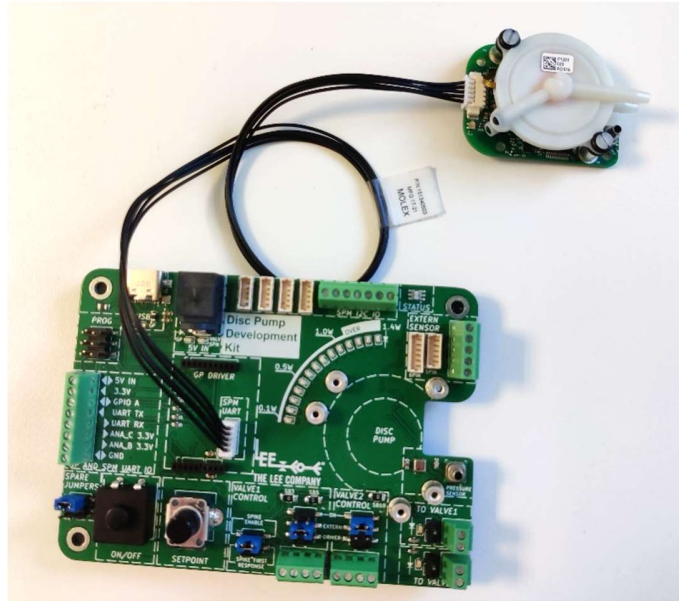

Figure 26 Smart Pump Module connected over UART to Development Motherboard

The Smart Pump Module will automatically connect via UART\* and can be controlled by the:

- SETPOINT dial on the Development kit motherboard (default Smart Pump Module behaviour).
- UART R/TX connections on the GP AND SPM UART IO screw terminal.
- Disc Pump Control App as described in Section 10.

*\* Note: Sometimes if the Development Kit motherboard is powered with the Smart Pump Module already connected it will fail to automatically select UART. To fix this unplug and plug the Smart Pump Module into the already powered on Development Kit motherboard or see Section 9.1.4 for disabling the autodetection of I2C/UART and setting the module to only one protocol.*

### 9.1.3 Single Smart Pump Module via I2C

Connect the Smart Pump Module to the SPM I2C connector. Connect the mains power supply to the Development Kit motherboard.

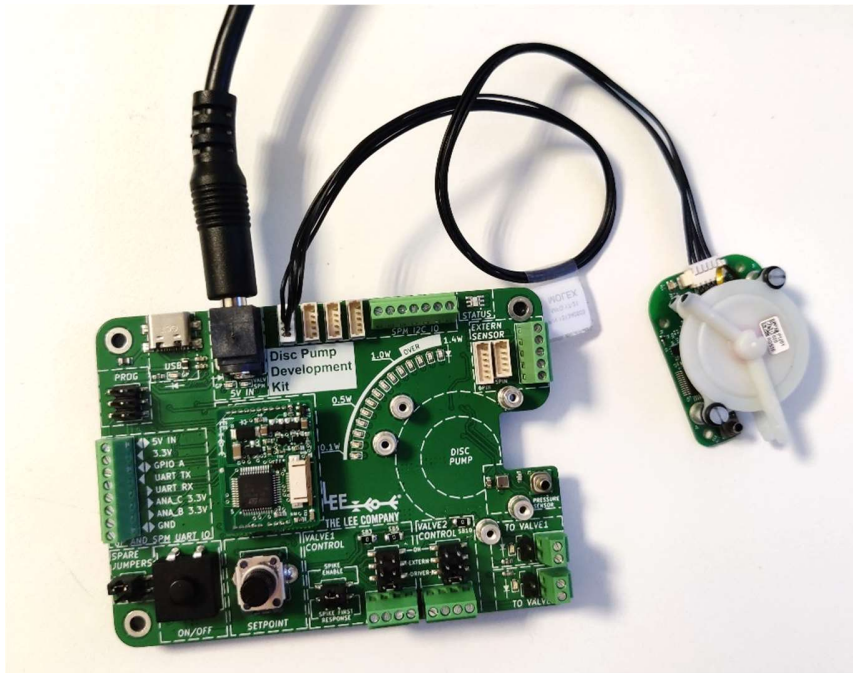

Figure 27 Smart Pump Module connected over I2C to the Development Motherboard. Mains power supply connected.

The Smart Pump Module will automatically connect via I2C\* and can be controlled by the:

- Analog input from on the SPM I2C IO screw terminal (default Smart Pump Module behaviour).
- I2C SDA/SCL connections on the SPM I2C IO screw terminal.
- Disc Pump Control App as described in Section 10.

*\* Note: Sometimes if the Development Kit motherboard is powered with the Smart Pump Module already connected it will fail to automatically select I2C. To fix this unplug and plug the Smart Pump Module into the already powered on Development Kit motherboard or see Section 9.1.4 for disabling the autodetection of I2C/UART and setting the module to only one communication protocol.*

### 9.1.4 Configuration of multiple Smart Pump Modules via I2C

When multiple Smart Pump Modules are connected via I2C the following settings need to be configured:

- Connect one of the Smart Pump Module to Development Motherboard and connect it to the Disc Pump Control App. Open the settings menu as shown in Figure 28 step 1.
- Give the Smart Pump Module a unique I2C address by writing the address to register 42 I2C Address as shown in Figure 28 step 2.
- Set the Smart Pump Module to I2C only mode by writing 1935 to register 43 I2C/UART Selection as shown in Figure 28 step 3. Note that this is only available with the Smart Pump Module Firmware version 5.6 and above.
- Save the settings to the Smart Pump Module by clicking the Use Current Settings on Startup button as shown in Figure 28 step 4. You will be prompted to confirm that you want to use the settings on startup, click Yes.
- Restart the Smart Pump Module by powering down the Development Motherboard and reconnecting it to power (disconnect both the power and USB cables then reconnect both).
- Repeat the setup steps (with a different I2C address) for the following Smart Pump Modules as shown in as shown in Figure 28 steps 5 through 8.

For more information on how to access the Settings menu see Section 10.9 The range of values and further information can be found in the 'TG003: Communications Guide'.

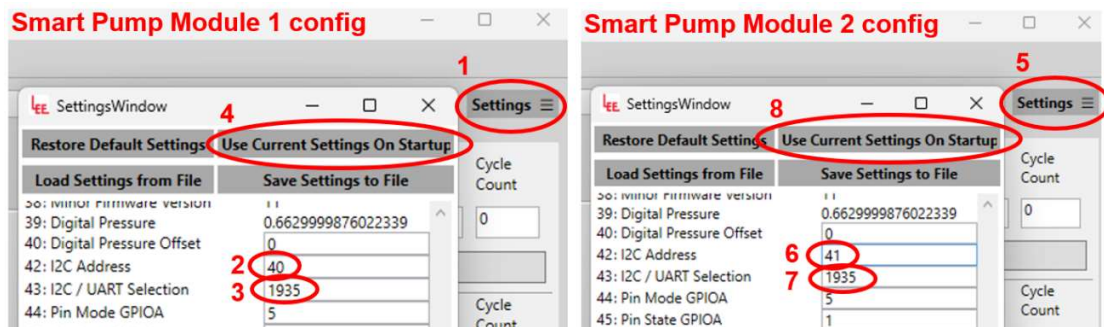

Figure 28 Configuring two Smart Pump Modules to be used at the same time over I2C. Note that Smart Pump Module needs to be restarted after acknowledging the Use Current Settings on Startup (step 4 and 8).

Note that controlling multiple pumps may cause performance issues on some computers. The typical performance issues are low framerate on the application or the graph appearing blocky. One way of mitigating the low framerate is to hide some of the plot tabs, reduce the number of variables that are plotted or reduce the Plot time axis as described in Section 10.3. The graph appearing blocky can happen with Smart Pump Modules connected over I2C, if the Smart Pump Module is using an old Firmware version (before v6.16). If this is the case, contact your local Lee representative for further information on how to upgrade the Firmware version. This plotting artifact can also happen if too many Smart Pump Modules are connected over I2C.

## 9.2 Controlling valves

### 9.2.1 Valve driving capabilities

The Development kit motherboard is equipped with one Spike and hold valve driver (Valve 1) and one Standard valve driver (Valve 2) that are controlled by the General Purpose driver on the Motherboard. Note that the **Smart Pump Module is not capable of driving valves**. Note that driving valves **requires the Mains power supply** which is not included in kit and relevant ordering information can be found in Section 11.2. Also note that the valves are not included in the Development Kit and relevant ordering information can be found in Section 11.4.

The Spike and hold valve driver (Valve 1) is specially designed to work with a High speed Lee Co. VHS valve, which have very fast switching times (see [Table 3](#) for VHS maximum operating frequency). In this mode the valve driver generates a 12V spike for 0.75ms (1A max) and then holds the output at 1.8V (1W max).

It can also be configured to work with a Lee Co. HDI valve or any standard 12V valve at maximum 2W.

| Ambient temperature | Duty cycle | Maximum frequency for VHS valve operation |
|---------------------|------------|---|
| 20°C                | 25%        | 50Hz                                      |
|                     | 50%        | 45Hz                                      |
|                     | 100%       | 30Hz                                      |
| 40°C                | 25%        | 25Hz                                      |
|                     | 50%        | 20Hz                                      |
|                     | 100%       | 5Hz                                       |

Table 3 VHS valve maximum operating frequency. The maximum frequency is considered as a rolling average over 5 seconds. Note that the maximum frequency can be increased through active cooling on the valve.

The Standard valve driver (Valve 2) is capable of driving a Lee Co. HDI valve or any standard 12V valve. Its maximum output is 12V at maximum 2W.

Table 4 summarizes how set up the board jumpers to drive different valves.





|  | VALVE 1 CONTROL  | VALVE 2 CONTROL  |
|--|--|--|
| <p>VHS ® valve – 12V spike</p>  | <p>Set the VALVE 1 CONTROL jumper to SPIKE ENABLE</p>            | <p>Valve driver 2 is NOT compatible with VHS ® valves.</p>                   |
| <p>HDI ® valve – 12V</p>       | <p>Remove the VALVE 1 CONTROL jumper from the spike header</p>  | <p>Valve driver 2 is compatible with HDI ® valves and requires no setup.</p> |

Table 4 Development motherboard jumper configurations for driving different valves.

Note that the Smart Pump Module is not capable of driving valves.

Note: To prevent losing the jumpers, spare jumpers can be stored on the JUMPER STORAGE pins.

To connect the valves, plug them into either the pins or screw terminals on the bottom right (TO VALVE 1/2). Also connect the Mains power supply which is required to drive the valves. Note that orientation does not matter. Note that next to each valve output there is an LED indicating if the valve is on or off.

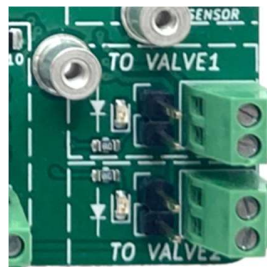

Figure 29 Terminals for connecting valves. Each terminal has an adjacent LED showing the state of the valve.

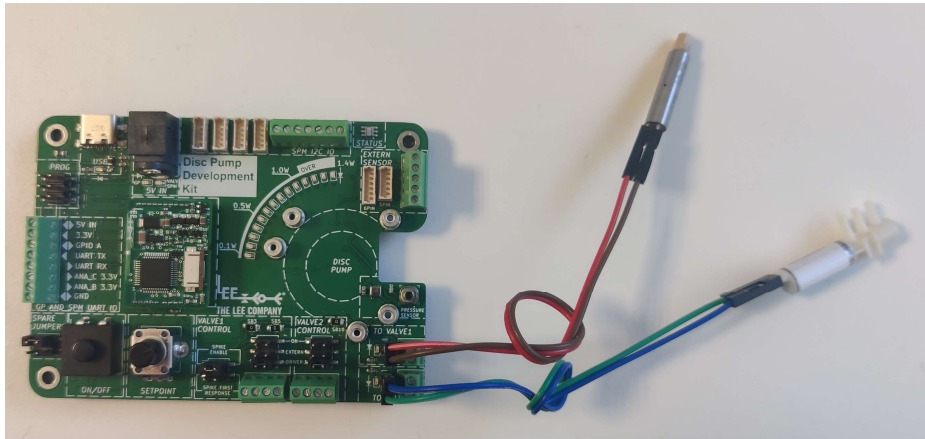

Figure 30 Development Kit with connected to a VHS valve (Valve controller 1) and an HDI valve (Valve controller 2).

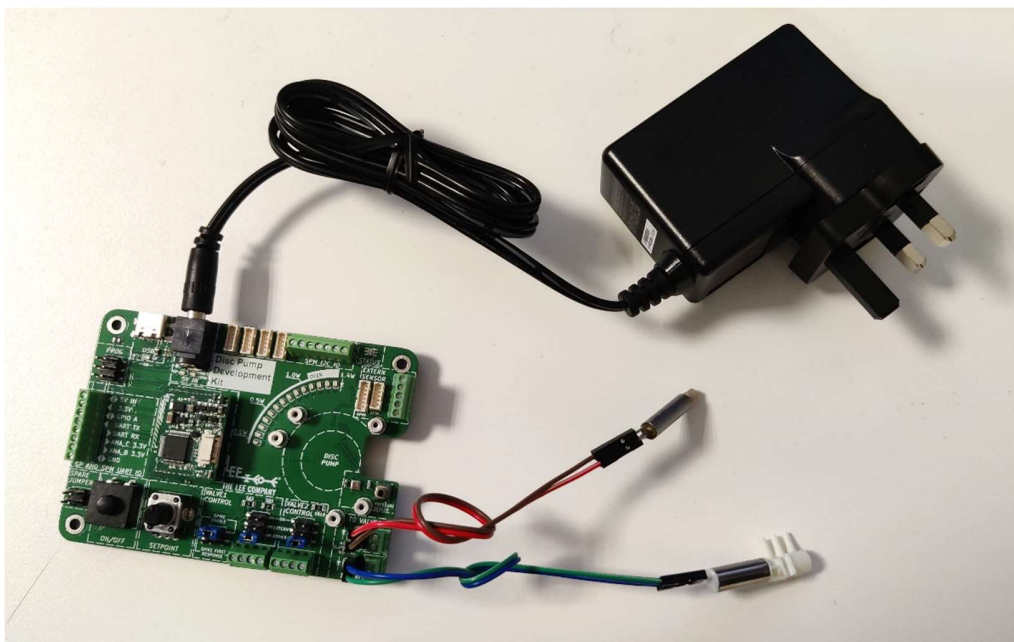

Figure 31 Development Kit with connected to two valves and the mains power supply (required for operating valves).

The valves can either be controlled manually by setting the jumper to ON or by setting it to DRIVER and using the Disc Pump Control application as described in Section 10.4.

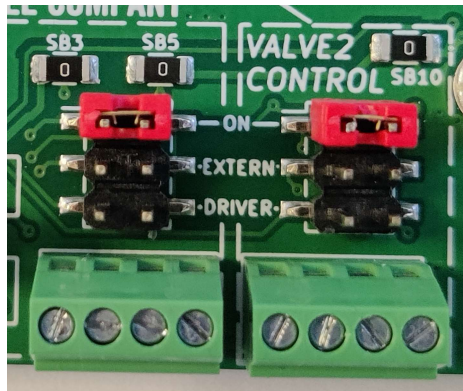

Figure 32 Manually turning the valves on

## 9.2.2 External controls and voltages

By default both valve drivers are controlled by the General Purpose drive board. Valve 1 is connected to GPIO B and Valve 2 is connected to GPIO C. The source of the control signal is set by the jumpers on the Valve control panels:

- Setting the jumper to ON manually turns on the valve as shown in Figure 32.
- Setting the jumper to EXTERN uses the external input from the screw terminals as shown on the left in Figure 33. This signal needs to be between 3.3V and 5V and the control pin on the terminal is indicated on the back of the board.
- Setting the jumper to DRIVER uses the relevant GPIO pin on the General Purpose driver (default) as shown on the right in Figure 33.

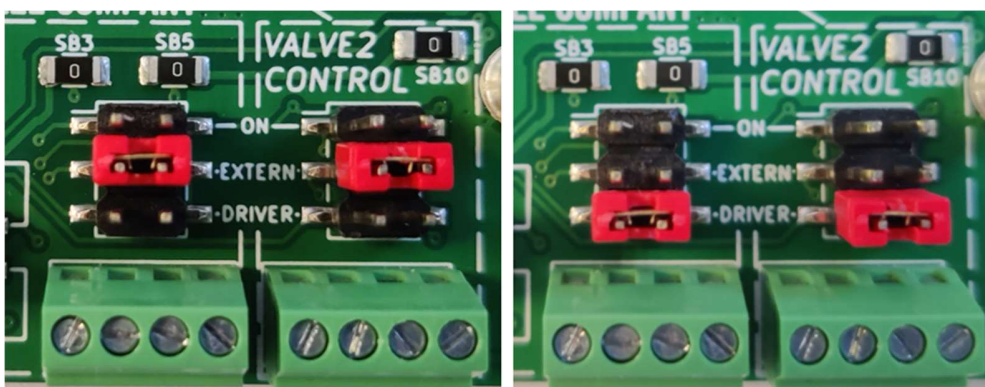

Figure 33 Valve drivers configured to be controlled by an external signal (left) and by the General Purpose driver on board (right)

Both valve drivers can drive valves of different voltages by providing an external power supply. To use an external power supply first a solder bridge needs to be removed to disconnect the on-board power supply as summarised in Table 5. The voltage pins of the screw terminals are indicated on the back of the board.



| Valve voltage                            | Solder bridge to remove   | Maximum ratings   |
|--|---|---|
| Valve 1 – Spike and hold – Spike voltage | SB5<br>    | 24V max<br>1A max   |
| Valve 1 – Spike and hold – Hold voltage  | SB3<br>  | <b>Hold voltage &lt; Spike voltage</b><br>24V max<br>1A max |
| Valve 1 – Standard valve driver voltage  | Same as Valve 1 spike voltage   |   |
| Valve 2 – Standard valve driver voltage  | SB10<br> | 24V max<br>1A max   |

Table 5 Development motherboard solder bridges for driving valves with external power supply.

### 9.2.3 Valve troubleshooting

Lee solenoid valves use an elastomer to create a leak-tight seal. Due to the elastomer's inherent stiction, extended periods of valve inactivity may have an impact on the initial response time of the valve. Allowing liquid to dry out in the valve will also impact valve response time.

If a valve has been stored for an extended period of time, it is recommended to toggle the valve a few times before using it. For VHS valves it is recommended to use the FIRST RESPONSE spike as shown in Figure 34. Do not use the FIRST RESPONSE spike for typical operation of the VHS valve as it can lead to excessive heating of the valve.

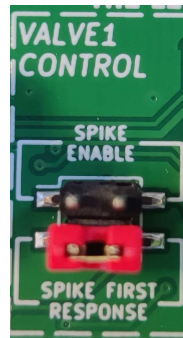





Figure 34 First response spike for VHS valves

### 9.3 External sensors / analog inputs

#### 9.3.1 Digital flow sensors from Sensirion

The Development kit supports a range of digital air and liquid flow sensors from Sensirion as shown in **Table 6**. Note that the digital flow sensors can only connect to the General Purpose driver on the Motherboard and cannot be directly used with the Smart Pump Module.

| Sensor series                                 | Medium and range                 | Image  |
|---|----------------------------------|--|
| SLF3S by Sensirion                            | Liquid<br>2 ml/min – 600 ml/min  |    |
| LD20 by Sensirion                             | Liquid<br>300 µl/min – 16 ml/min |   |
| LPG10 by Sensirion                            | Liquid<br>1 ml/min               |  |
| LG16 by Sensirion<br>(digital sensor variant) | Liquid<br>1.5 µl/min - 5ml/min   |  |



|   |                                   |   |
|---|-----------------------------------|---|
| <p>SFM6000 by Sensirion</p>   | <p>Gas<br/>5 L/min – 50 L/min</p> |   |
| <p>SFC6000 by Sensirion<br/>Note that the valve on the sensor cannot be controlled by the driver board.</p> | <p>Gas<br/>5 L/min – 50 L/min</p> |  |

Table 6 External sensors compatible with the Development Kit. Images source: <https://sensirion.com/>

The LSF3S and LG16 sensors plug directly into the 6pin and 5pin headers on the board respectively as shown in Figure 36. The others can be connected to the screw terminal on the right of the board – please check the pinout on the back of the board and the sensor datasheet for. The screw terminal has 3.3V and 5V stable supplies for sensors (100mA max).

The flow sensor needs to be connected to the Development kit when the kit is turned off. If the kit is powered on when the sensor is connected, the sensor will not be recognised by the system. This happens because the driver only checks for connected sensors upon system startup. If the sensor uses external power (e.g. the SFM6000 requires external 24V) the following sequence needs to be followed:

- Turn off the Development kit and the sensor.
- Connect the sensor to the Development kit.
- Power the sensor.
- Turn on the Development kit.

*Note that the Molex Picoblade 6pin female-female cable required for the LSF3S sensors is not included in the kit. The Molex Picoblade 5pin female-female cable required for the LG16 sensors is included in the kit. Off the shelf cables can be found on online electronics retailers such as Mouser or RS Components.*

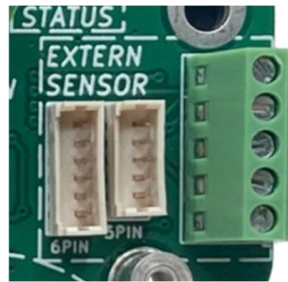

Figure 35 Connectors for external digital sensors.

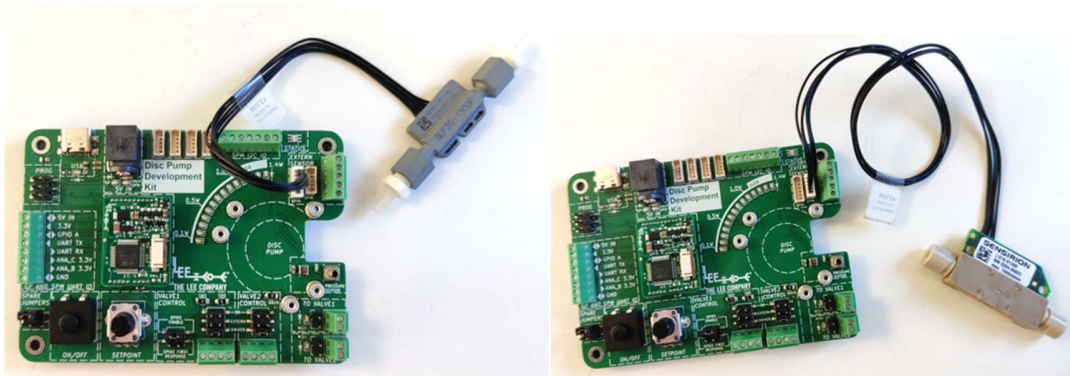

Figure 36 Development Kit connected with an LSF3S (left) and LG16 (right) external flow sensor.

The sensor data can be plotted in the Disc pump control app by enabling plotting of the “external flow sensor”. The sensor can also be used as input for PID control. Measurement units can be changed from the settings menu.

### 9.3.2 Analog sensors or analog inputs

Any analog sensor can be used to control the General Purpose Driver Board through the GPIO AND SPM UART IO screw terminal (as shown in Figure 38) or to control a Smart Pump Module through the SPM I2C IO screw terminal. The pinout of the terminals can be checked on the back of the board.

To minimise sensor noise, it is recommended to connect the sensor to the accurate and stable external 3.3V or 5V supplies (100mA max) using the EXTERN SENSOR screw terminal. This is shown in Figure 38 and the pinout of the terminal can be checked on the back of the board. The sensor can also be used as the input for PID control, as described in more detail in Section 10.6.

*Note that the driver boards accept a maximum of 3.3V so if the sensor output is higher it will need to be stepped down with a resistive potential divider.*

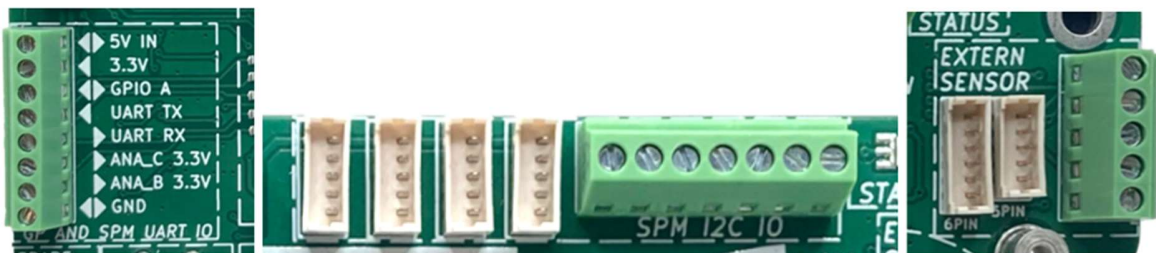

Figure 37 Screw terminals for connecting analog sensors to the Development Kit. The sensor output can be connected to the GP driver or SPM UART IO (left) or SPM I2C IO (centre) and should be powered by the regulated voltage output of the EXTERN SENSOR connector (right). The pinout of the terminals can be checked on the back of the board.

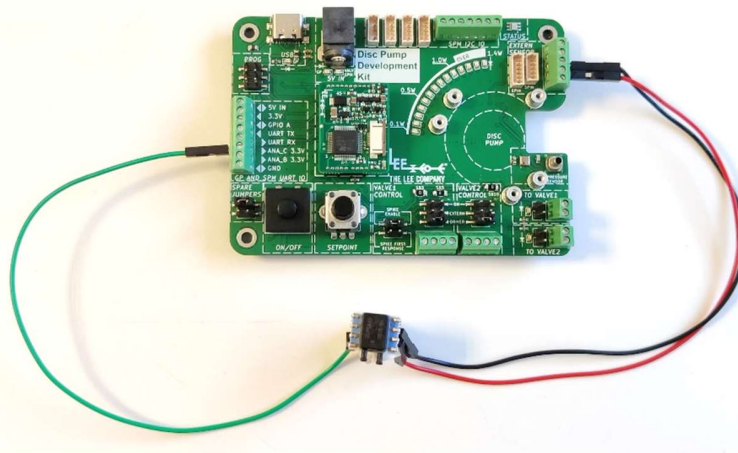

Figure 38 Analog pressure sensor connected to GP driver. Sensor is powered by the stable 3.3V for sensors.

## 10 DISC PUMP CONTROL APP

### 10.1 Setup

To configure the PCB, a bespoke application (Disc Pump Control App) is available on The Lee Company website - <https://theleeco.com/DevKit>. Note that the application is only supported on Windows.

To download the relevant drivers:

- Ensure the PC is connected to the internet.
- Connect the PCB to the PC with the USB cable.
- If the PC is running Windows 7 or later, all drivers should automatically be downloaded and installed.
- Drivers for the Development kit can be downloaded from <https://www.microchip.com/en-us/product/mcp2200>
- Drivers for the old Evaluation kit can be download from here: <https://ftdichip.com/drivers/vcp-drivers/>
- If Microsoft .NET framework is not installed then running the app may result in an error message like the one below. Usually, the prompt automatically opens the download page for the relevant .NET version. Alternatively .NET can be downloaded from there (if in doubt about the required version, install the latest version): <https://dotnet.microsoft.com/en-us/download/dotnet>. Note that this installation requires admin privileges on the computer.

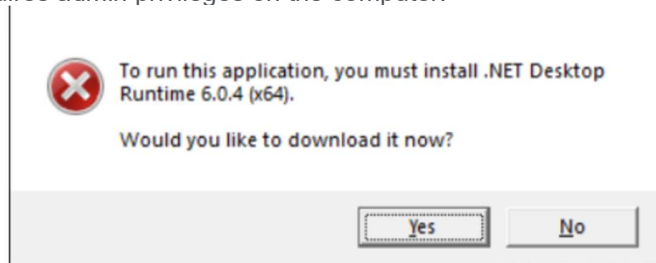

Figure 39 Error message when running the Disc Pump Control app if the required version of .NET is not installed.



#### CAUTION

Ensure that the driver installation process has completed successfully before proceeding

## 10.2 Getting started

### 10.2.1 Overview

### 10.2.2 Connecting a driver board

With the PCB connected to the PC via the USB cable, double click on the “Disc Pump Control App.exe” executable file.

- Select the appropriate COM port from the top-left dropdown menu and click connect as shown in Figure 40. The COM port can easily be found by plugging and unplugging the kit and observing which COM port appears and disappears.
- If using a Smart Pump Module connected over I2C click the Scan I2C button on the top left. Once the scan is completed you can access the I2C devices from the Port dropdown menu and click connect as shown in Figure 40.
- Click on the “+” button to create a plot tab as shown in Figure 41.
- The application should now be connected and display all the current settings on the GUI as shown in Figure 42.



Figure 40 Connecting a driver board to the Disc Pump Control App

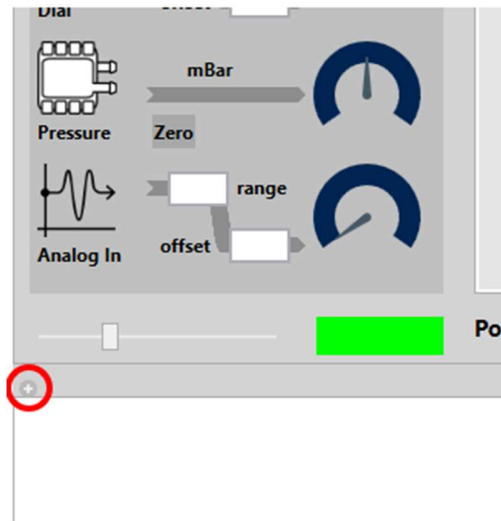

Figure 41 Creating a plot window.

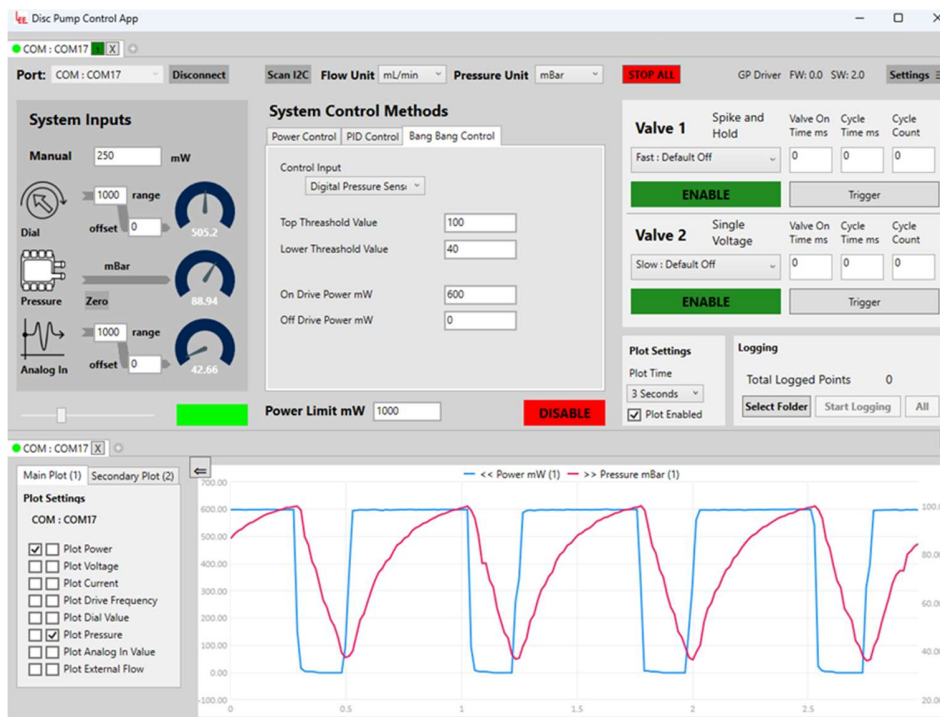

Figure 42. Disc Pump Control App GUI

### 10.2.3 System inputs

The user interface has a panel displaying the System Inputs on the left-hand side as shown in Figure 43 – these are:

- A manual setpoint entered via the software.
- The setpoint dial on the Development motherboard and Evaluation kit motherboard.
- The pressure sensor.
- A 0 to 3.3V analog input signal on the screw terminal block.

The values for these inputs are displayed under the dials on the user interface.

The dial and analog-in inputs have a range and an offset associated with them. This allows these inputs to be arbitrarily mapped to power and pressure setpoint variables.

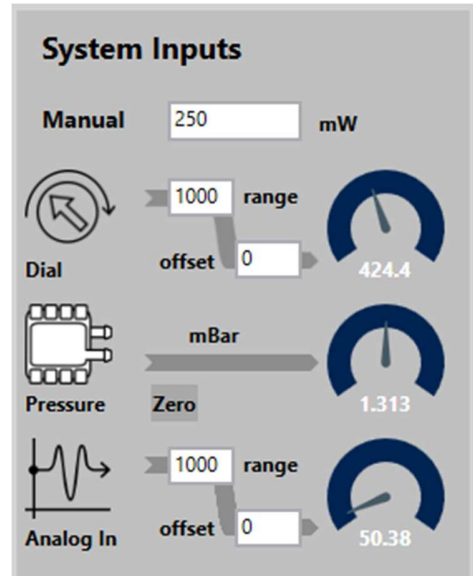

Figure 43 System inputs

### 10.2.4 System controls methods

In the centre of the user interface is the System Control Methods panel. There are three control modes:

- Power Control,
- PID pressure control,
- Bang-bang pressure control.

#### 10.2.4.1 Power control mode

Power Control mode controls the drive power supplied to the pump.

- Select the Power Control tab.
- Select the target power source from the dropdown menu:
  - **Manual:** the power target is entered manually into the “System Input” section. The units are milliwatts.
  - **Dial:** the power target is controlled by the position of the SETPOINT potentiometer control on the motherboard.
  - **Analog Input (B or C):** the power target is controlled by the 0 to 3.3V analog input supplied on the external connections screw terminal block on the motherboard.
  - Note that the potentiometer and analog in control input values are displayed in the “System Inputs” section of the PC application. Each has a range and offset associated with it, allowing the mapping of the input to the target power to be configured. Example mappings:

| Desired full-scale range mapping | Range | Offset |
|----------------------------------|-------|--------|
| 0 to 1000 mW                     | 1000  | 0      |
| 0 to 500 mW                      | 500   | 0      |
| 200 to 400 mW                    | 200   | 200    |

Table 7: Example mappings of the Range and Offset variables

- Click the “Enable/Disable” button on the GUI to toggle the pump output. Alternatively, use the ON/OFF button on the motherboard.
- Tick the “Plot Power” check box to observe the drive power supplied to the pump.

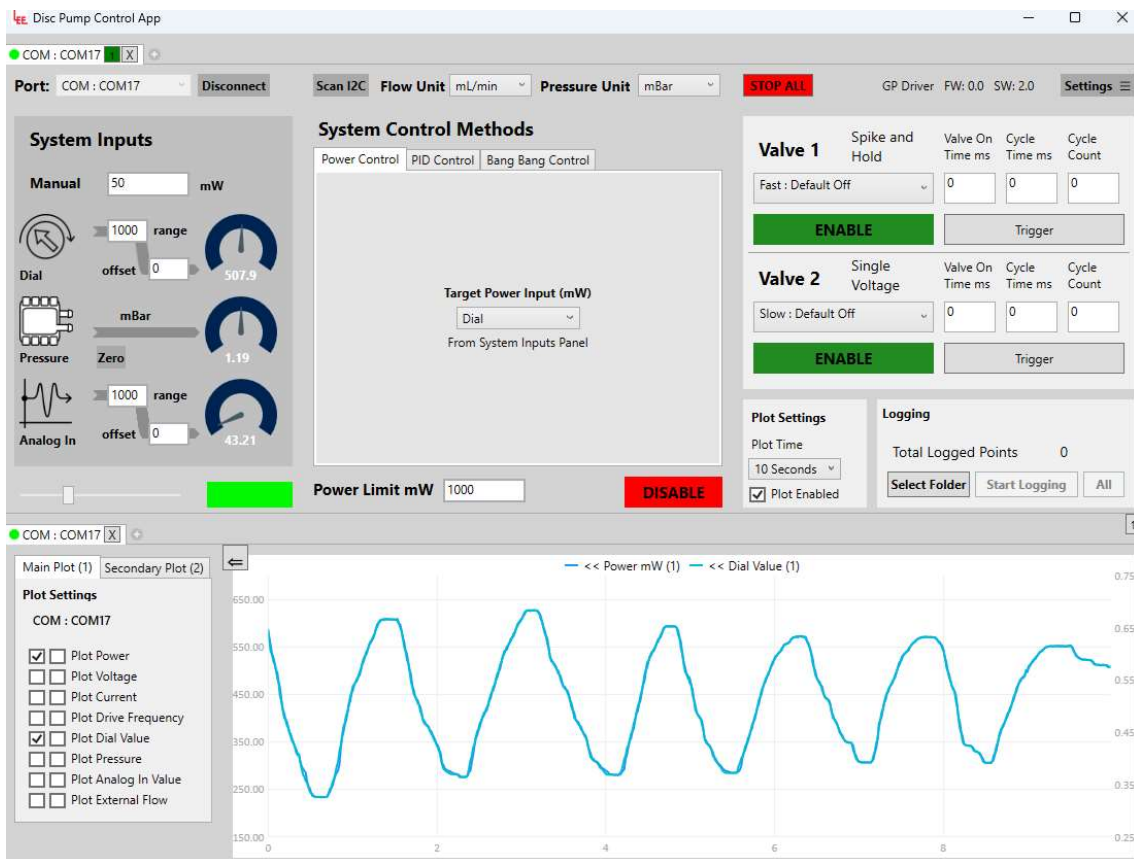

Figure 44. Power controlled to a target controlled by the SETPOINT dial on the motherboard.

#### 10.2.4.2 PID control mode

PID Control mode adjusts the pump drive power until a target pressure or flow is reached.

---

#### TAKE NOTE

Connect the barb of the pressure sensor to the pneumatic circuit.

**For positive pressure control**, connect the pressure sensor to the outlet of the pump. Within the control app, use positive pressure setpoint targets and positive values for the P, I and D coefficients which determine the behaviour of the PID control loop.

**For negative pressure control**, connect the pressure sensor to the inlet to the pump. Within the control app use negative pressure setpoint targets and negative values for the P, I and D coefficients which determine the behaviour of the PID control loop.



The pressure sensor reading can be zeroed by clicking the “Zero” button next to the pressure sensor icon. Pressure reading must be zeroed when changing pressure units.



- 
- Connect the on-board pressure sensor to the pneumatic circuit.
  - Select the PID Control tab.
  - Select the pressure control setpoint from the dropdown menu:
    - **Manual:** the pressure target is entered manually into the “System Input” section
    - **Dial:** the pressure target is controlled by the position of the SETPOINT dial control on the motherboard.
    - **Analog Input (B or C):** the power target is controlled by the 0 to 3.3V analog input supplied on the external connections screw terminal block on the motherboard.
    - Note that the dial control input value is displayed in the “System Inputs” section of the PC application. It has a range and offset associated with it, allowing the mapping of the input to the target pressure to be configured. Example mappings for the Dial control are:

| Desired full-scale range mapping | Range | Offset |
|----------------------------------|-------|--------|
| 0 to 100 mBar                    | 100   | 0      |
| 0 to 200 mBar                    | 200   | 0      |
| 100 to 200 mBar                  | 100   | 100    |

Table 8: Example mappings of the Range and Offset variables

- **Input:** Select 'Digital Pressure Sensor' from the drop-down list.
- Click the "Enable/Disable" button on the GUI to toggle the pump output. Alternatively, use the ON/OFF button on the motherboard.
- Tick the "Plot Pressure" check box to observe the pressure measured by the sensor.
- The P, I and D coefficients should be configured to optimise performance of the loop for the customer's specific setup. Factors such as the volume of the pneumatic circuit need to be considered when tuning the pressure control loop.

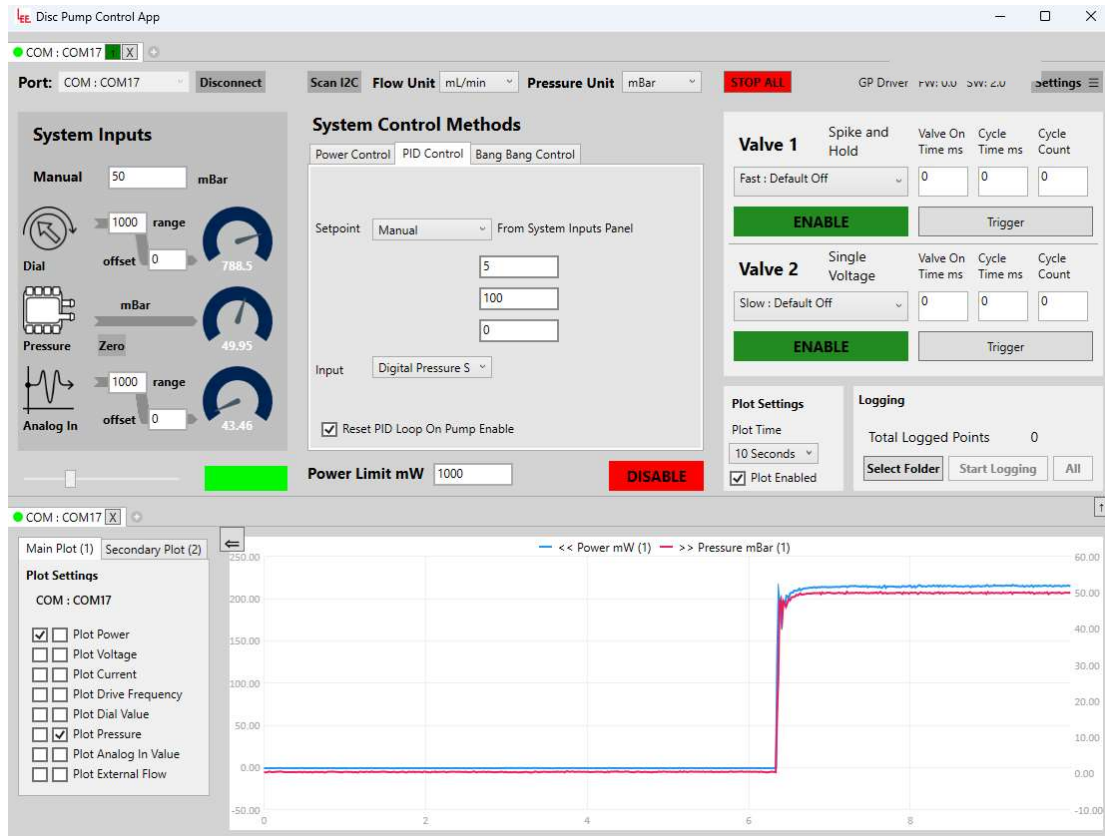

Figure 45. Pressure controlled to 50mBar under PID control mode

10.2.4.3 Bang Bang Control Mode (positive pressure only)

“Bang Bang” control mode is a simple on-off controller that switches the pump on and off to control the output pressure between two defined pressure limits.

- Connect the on-board pressure sensor to the pneumatic circuit.
- Select the Bang Bang Control tab.
- Enter the top pressure limit in the Top Threshold field.
- Enter the lower pressure limit in the Low Threshold field.
- Enter a value for On Drive Power mW – this is the drive power supplied to the pump when it is on (after the lower threshold value is reached); if in doubt, start with 1000 mW, but reduce it if the pressure overshoots above the top threshold is an issue, or to reduce the rate of inflation.
- Enter a value for Off Drive Power mW – this is the drive power supplied to the pump when it is off (after the top threshold value is reached); if in doubt, start with 0 mW, but increase it if the pressure undershoots above the lower threshold is an issue, or to reduce the rate of deflation.
- Click the “Enable/Disable” button on the GUI to toggle the pump output. Alternatively, use the ON/OFF button on the motherboard.
- Tick the “Plot Pressure” check box to observe the pressure measured by the sensor.

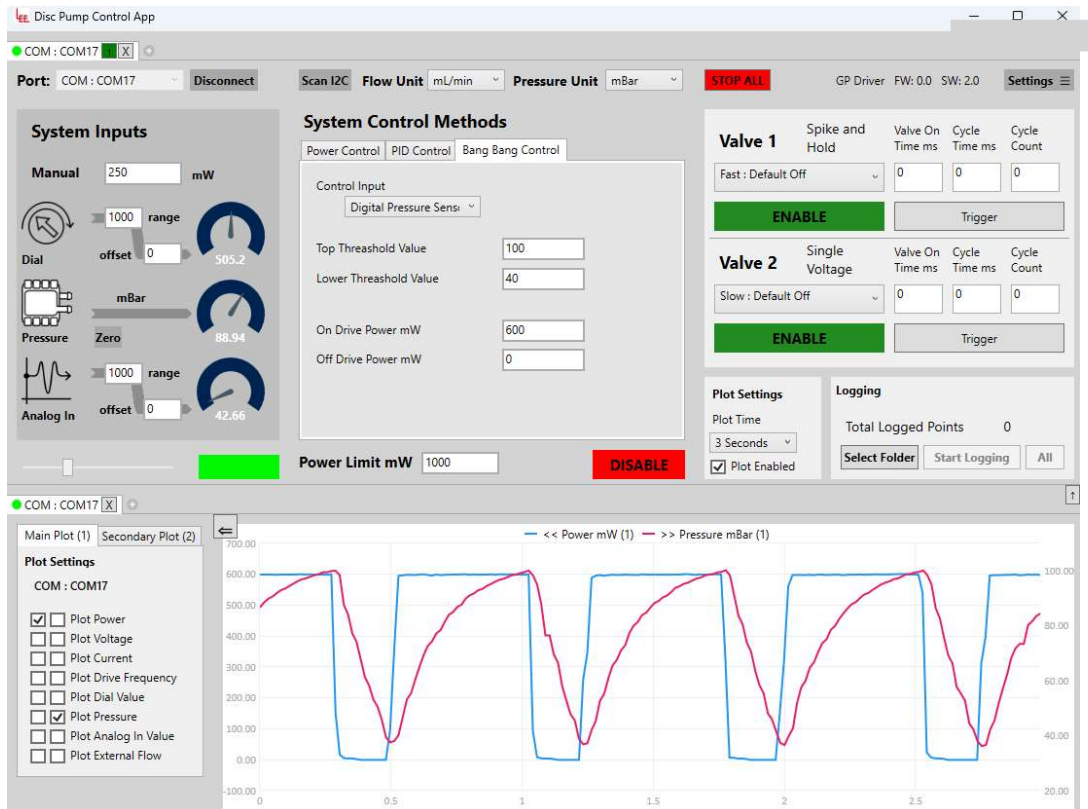

Figure 46. Pressure cycling between two limits under bang-bang control

### 10.2.5 Power limit

The driver board has a function to limit the drive power supplied to prevent damage to the pump. The “Power Limit mW” field allows this limit to be set. Initially, we recommend that this limit is set to 1000 mW. For intermittent (i.e. non-continuous) use, higher limits can be used up to a maximum of 1400 mW. Intermittent use is defined as having:

- Mean power  $\leq$  1000 mW
- A duty cycle period of less than 20 s.



Figure 47 Pump power limit.

### 10.2.6 Measurement units

The driver board can be configured to report pressure and flow in a variety of measurement units. This option can be accessed from the two dropdown menus on the top of the application. Note that this functionality is supported on the Smart Pump Module only for Firmware versions 6.16 and above.

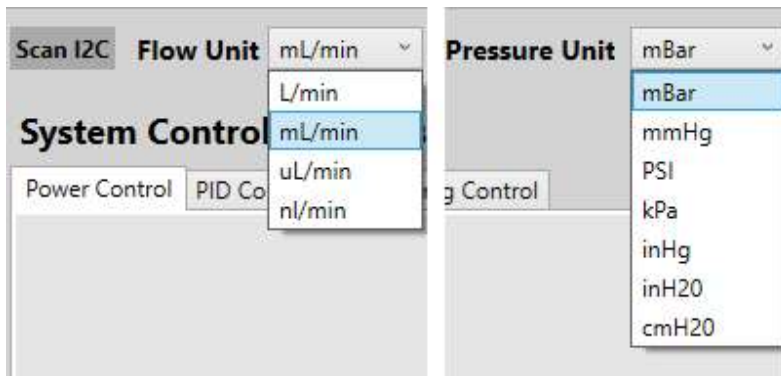

Figure 48 Selecting measurement units for flow and pressure.

The pressure must be zeroed after changing the Pressure Unit.



Figure 49 Zeroing the pressure sensor.

Note that the choice of pressure / flow unit affects the PID values required for good control. The PID calculation is dimensionless, and so will treat a change of 1mBar (when measuring pressure in mBar) as equivalent to a change of 1PSI (when measuring pressure in PSI) because they are both changes of “one unit of pressure”. Therefore, the values of P, I and D need to be set appropriately for the pressure units used.

For example, a P value of 10 is used when the system was controlling to pressure in mBar. If the system is switched to use pressure in PSI, P needs to be set to  $69 * 10 = 690$  (as 1PSI = 69mBar) to achieve the same response.

### 10.3 Plotting

Click on the “+” button to create a plot tab as shown in Figure 50. Note that when a plot tab is created it is tied to the last active pump control tab (the last one that was clicked on) and therefore will display the output of that pump.

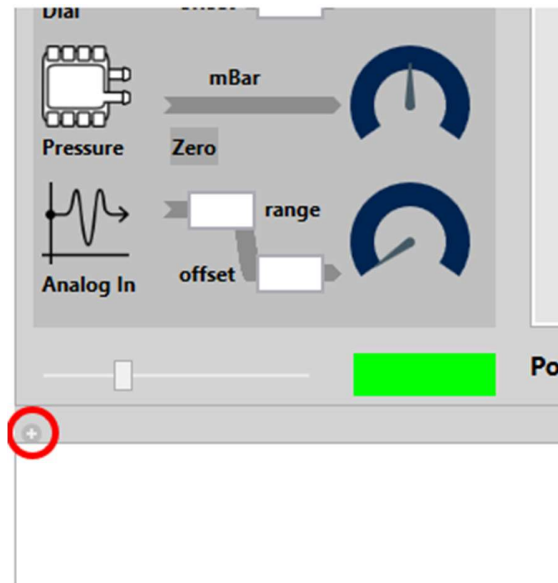

Figure 50 Creating a plot window.

#### 10.3.1 Plotting data from a single pump

Various parameters can be plotted on the graph presented in the PC application.

- Tick the check boxes on the left to confirm the values to be plotted. The left most column of tick boxes corresponds to plotting the data on the left Y axis and the right hand column of tick boxes corresponds to plotting the data on the right Y axis (as shown in Figure 51).
- On the top of the graph there is a legend of all data sets plotted. The legend contains arrows next to each data set to indicate whether it is plotted on the left or right Y axis.
- It is possible to zoom on the graph by scrolling whilst hovering over it with the mouse cursor.
- Panning up and down the Y axis is possible by clicking and dragging up and down.
- The value at a given point for a given curve on the graph can be displayed by rolling over the point with the mouse cursor.

*Note that plotting data from Smart Pump Modules connected over I2C may appear blocky or in steps. This can happen if the Smart Pump Module is using an old Firmware version (before v6.16). If this is the case, contact your local Lee representative for further information on how to upgrade the Firmware version. This plotting artifact can also happen if too many Smart Pump Modules are connected over I2C.*

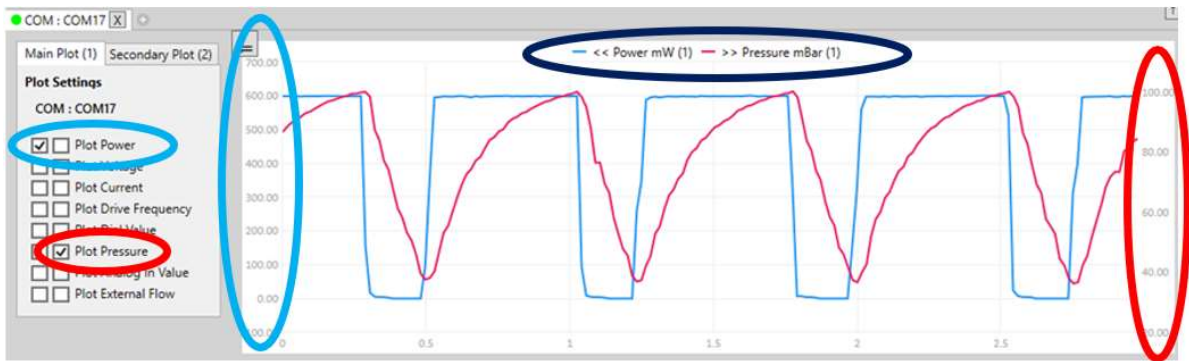

Figure 51 Plot with two axis. Plot power on the left Y axis in blue and pressure on the right Y axis in red.

The plot can be paused by clicking on the Plot Enable tick box. The X time axis resolution can be set by the dropdown menu Plot Time.

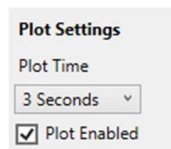

Figure 52 Plot settings - pausing the plot and setting the plot time axis.

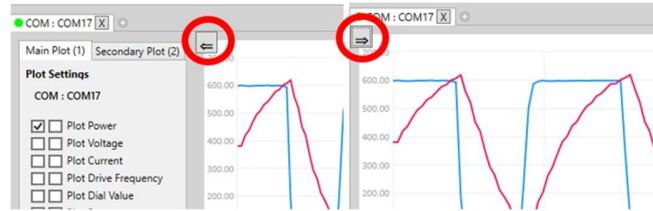

Figure 53 Showing and hiding the plot settings.

### 10.3.2 Plotting data from multiple pumps

The data from two pumps can be plotted on the same graph.

- Connect a second pump as explained in Section 10.7.
- Select the Secondary plot settings menu on the left.
- Select the second pump that should be plotted from the drop-down menu. Tick the check boxes for the values to be plotted.
- At the top of the graph there is a legend of all data sets plotted. The legend contains a (number) next to each data set to indicate whether it is data from the main (1) or secondary (2) pump as shown in Figure 54.



Figure 54 Plotting data from multiple pumps. Data from the main pump is plotted in red and data from the secondary pump is plotted in orange.

Note that controlling multiple pumps may cause performance issues on some computers. The typical performance issues are low framerate on the application or the graph appearing blocky. One way of mitigating the low framerate is to hide some of the plot tabs, reduce the number of variables that are plotted or reduce the Plot time axis as described in Section 10.3. The graph appearing blocky can happen with Smart Pump Modules connected over I2C, if the Smart Pump Module is using an old Firmware version (before v6.16). If this is the case, contact your local Lee representative for further information on how to upgrade the Firmware version. This plotting artifact can also happen if too many Smart Pump Modules are connected over I2C.

## 10.4 Valve control

The valve control interface can be found on the top right and is used to turn valves on and off or generate multiple pulses. Valve wiring and valve options are described in more detail in Section 9.2. Note that this interface is only available with a General Purpose drive board (the Smart Pump Module cannot control valves) and is controlled through the GPIO pins on the board. Note that driving valves requires the Mains power supply which is not included in kit and relevant ordering information can be found in Section 11.2.

The screenshot shows a software interface for controlling two valves. It is divided into two main sections, one for Valve 1 and one for Valve 2. Each section has a dropdown menu for pulse generation (Fast/Default Off for Valve 1, Slow/Default Off for Valve 2), three input fields for Valve On Time ms, Cycle Time ms, and Cycle Count, and a green ENABLE button. Below the Valve 2 section are two additional buttons: Toggle Both and Trigger Both.

| Valve 1            | Spike and Hold | Valve On Time ms | Cycle Time ms | Cycle Count |
|--------------------|----------------|------------------|---------------|-------------|
| Fast : Default Off |                | 0                | 0             | 0           |
| ENABLE             |                | Trigger          |               |             |
| Valve 2            | Single Voltage | Valve On Time ms | Cycle Time ms | Cycle Count |
| Slow : Default Off |                | 0                | 0             | 0           |
| ENABLE             |                | Trigger          |               |             |
| Toggle Both        |                | Trigger Both     |               |             |

Figure 55 Valve control interface.

The valves can be turned on or off using the ENABLE / DISABLE button. This can be used for operating static valves e.g. for redirecting air or liquid flow or venting the system.

The “Toggle Both” button switches the states of both valves (the same as pressing the ENABLE / DISABLE button on both valves simultaneously). This is useful in applications that require the two valves to switch at the same time e.g. in a reversible flow setup.

The interface can also be used to generate a train of pulses, which is useful for precision dispensing applications. This is configured through the right half of the interface:

- Valve On Time ms – this field indicates how many milliseconds the valve will be enabled for.
- Cycle Time ms – this field indicates the total cycle time of the pulse train. For example, if the on time is set to 3ms and the cycle time is set to 5ms, the valve will be on for 3ms and off for 2ms.
- Cycle count – this field indicates how many pulses will be generated. Note that the maximum number of pulses is 250.
- Trigger – starts the train of pulses.
- Trigger both – starts the train of pulses of both valves (the same as pressing the Trigger button on both valves simultaneously). This can be useful in applications that require synchronisation between the valves e.g. closing a vent valve and starting dispensing.

Take note that if using high speed VHS valves, the maximum frequency of operation needs to be considered due to thermal limitations as shown in Table 9.

| Ambient temperature | Duty cycle | Maximum frequency for VHS valve operation |
|---------------------|------------|---|
| 20C                 | 25%        | 50Hz                                      |
|                     | 50%        | 45Hz                                      |
|                     | 100%       | 30Hz                                      |
| 40C                 | 25%        | 25Hz                                      |
|                     | 50%        | 20Hz                                      |
|                     | 100%       | 5Hz                                       |

Table 9 VHS valve maximum operating frequency. The maximum frequency is considered as a rolling average over 5 seconds. Note that the maximum frequency can be increased through active cooling on the valve.

The valve controls have a few different modes accessible through the drop-down menu:

- Fast mode (**Valve 1 only**). In this mode the minimum time resolution for a pulse is 0.01ms (10us) and the maximum pulse duration is 300ms.
- Slow mode (both valves). In this mode the minimum time resolution is 1ms and the maximum pulse duration is 30000ms (30s).
- Default Off – when the valve is disabled its output is off and when enabled its output is on. Similarly, for pulses the Valve On time indicates how long the valve is enabled (output is on) and once the train of pulses is complete the valve is disabled (output is off).
- Default On – this setting inverts the valve operation and is used mainly for valves that need to typically be kept closed. When the valve is disabled, its output is ON and when enabled its output is OFF. Similarly, for pulses the Valve On time indicates how long the valve is enabled (output is OFF) and once the train of pulses is complete the valve is disabled (output is ON).

Valve control modes require rebooting the board to take effect and thus require clicking yes on the pop-up dialog box or by Use Current settings on startup in the Settings menu (see Section 10.9).

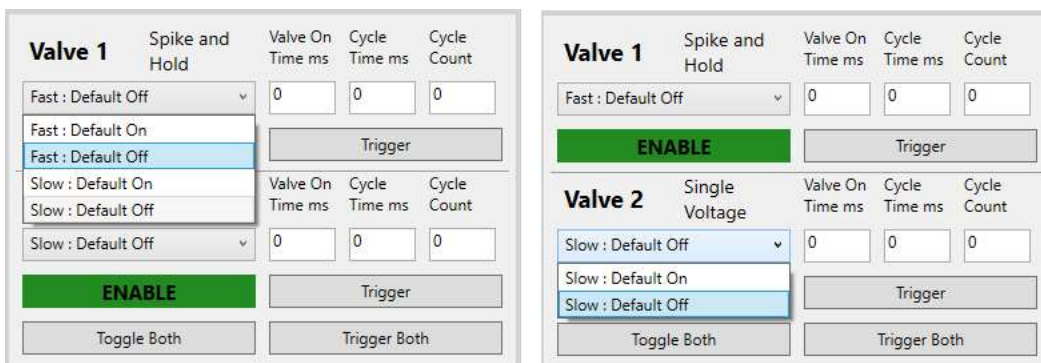

Figure 56 Valve control modes. Note that only Valve 1 supports Fast mode.

## 10.5 GPIO A

### 10.5.1 Toggling the pump output with GPIOA



Figure 57. GPIO A is used for gating

GPIO A on the screw terminal block is a 3.3V-level digital control input that enables toggling of the pump output. This pin is normally pulled high by the Disc Pump Driver PCB. A state change on this pin will toggle the enabled state of the pump. This functionality can be used as a simple means of enabling / disabling the pump from an external source. It can also act as a rudimentary gate, allowing higher frequency duty-cycling of the pump up to approximately 10 Hz.

Note that in the System Control Methods panel of the Pump Control App, there is a check box to reset the PID loop on pump enable. When checked, the “I” integral term of the PID loop will be reset each time the pump is enabled; when unchecked, the integral value will persist. In essence, when unchecked, the system’s closed-loop control behaviour is to ‘pick up where it left off’ through a gating cycle, whereas when checked the behaviour is to reset each cycle. For high frequency (>1 Hz) gating, it is recommended to leave this check box *unchecked*, as resetting the PID loop each cycle may cause undesirable results. For lower frequency gating and simple enable/disable functionality, this box should be checked/unchecked on a case-by-case basis, depending on the desired functionality.

### 10.5.2 Configuring GPIO A as an output

The pin mode of GPIO A can be set by using the Settings menu as explained in Section 10.9. The relevant settings for GPIO can be found in the “TG003: PCB Serial Communications Guide”. Note that changing the pin mode requires saving the settings and rebooting the board.

## 10.6 Using the Analog Inputs

The analog input can be used in a variety of ways to control of pump performance. This can be useful for initial system integration work, for example.

To control pump power      The analog input can be used to variably control the pump drive power. See Section 10.2.4.1 for further details.

To ‘gate’ the pump drive for short pulse control      The analog input is sampled at around 1kHz, enabling the pump to be switched on and off quickly to any desired power level using power control mode (see Section 10.2.4.1). This feature can be used to deliver a short pulse of air, e.g. for microfluidic control applications.

To control the output pressure setpoint      The analog input can be used to provide the target pressure for the on-board PID control loop, with the on-board pressure sensor being used to monitor the actual pressure. See Section 10.2.4.2 for further details.

As an input from an external pressure sensor      The analog input can be used as an input from an external pressure sensor to the on-board PID control loop, with the target pressure set manually or via the software. See Section 10.6.1 for further details.

### 10.6.1 Tracking pressure via the Analog Input

It is possible to use the Development kit to follow a specific pressure profile controlled through the analog input to the board. The following set up shows how this can be achieved.

For the purpose of this guide an XP parallel pump (part number UXPB5400000A) has been used. The same set up applies for any model disc pump providing that the pump discharge is connected as detailed below.

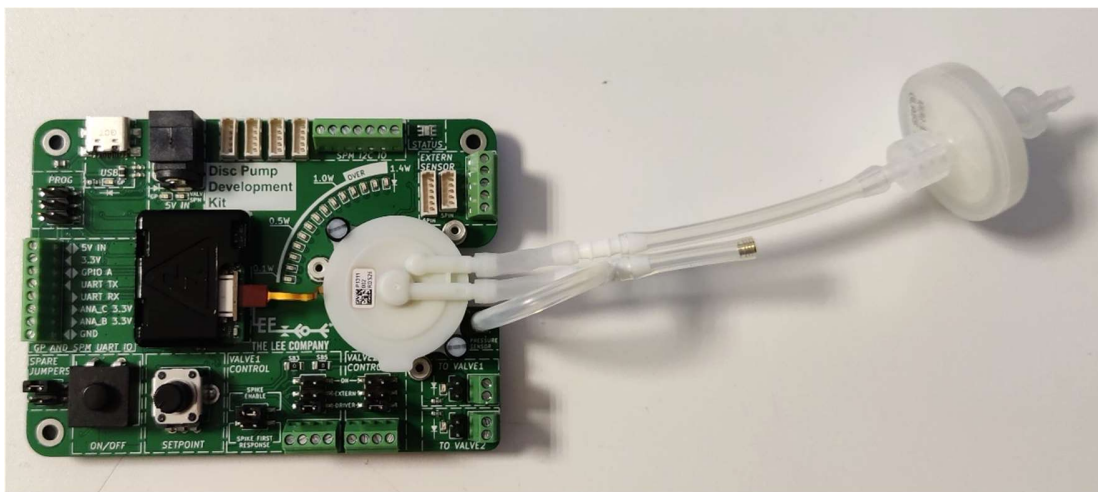

Figure 58. Pump setup tracking pressure via analog input

To set up pressure tracking:

- Connect the output of the pump to the PCB-mounted pressure sensor and to the orifice via a T-piece.

The orifice allows the pressure in the discharge line (or system) to decay when the pump is not running. The size of the vent orifice needed will depend on the pump performance, system requirements and the response time needed.

- Having set up the system as shown, open the Disc Pump Control App and select the PID Control tab.

For the purposes of this example, the setpoint dial on the PCB has been selected as the control input (Dial). To control using the analog input instead, select 'Analog Input' as the control input.

The range and offset parameters associated with the control input can be mapped as detailed in Section 10.2.4.2.

- In the second drop down box below the PID variables, select Digital Pressure Sensor. (This is the variable which is controlled by the PID loop to match the control input) as shown in Figure 59.
- Enable the pump.

The pump drive power will be adjusted by the PID loop to achieve the desired target pressure.

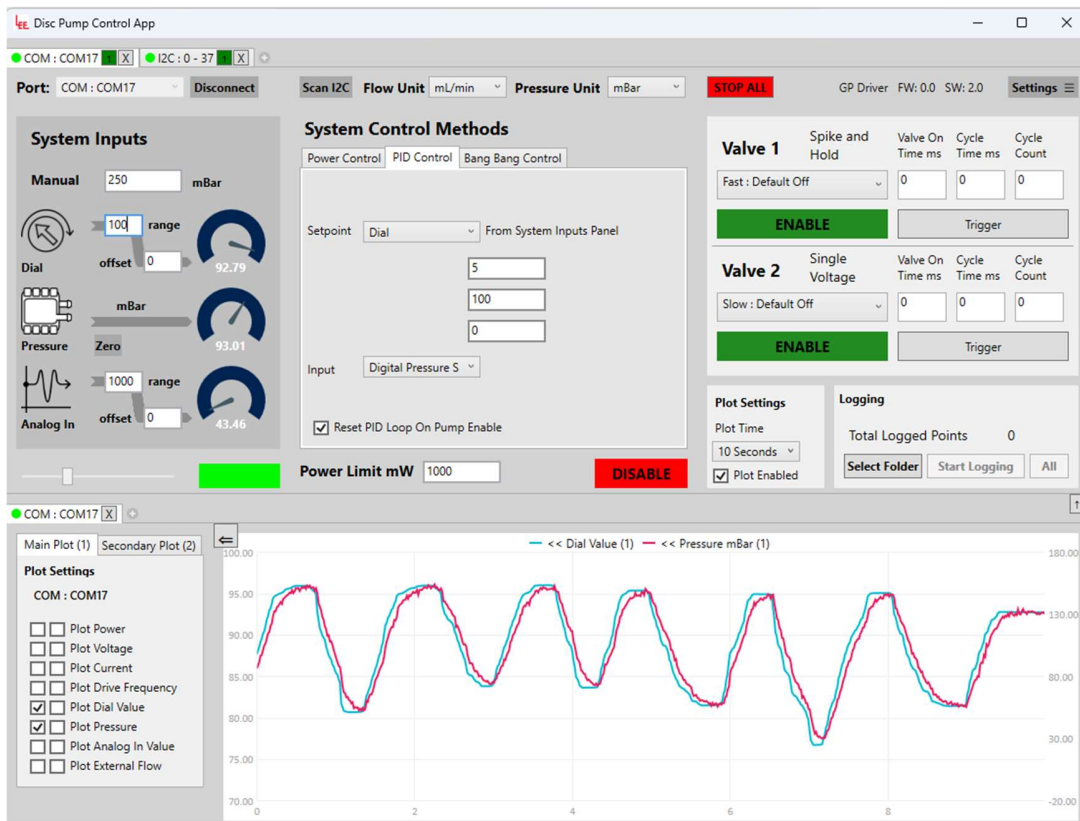

Figure 59 GUI showing PID control setup. Dial value shown in teal and pressure shown in red.

Figure 59 shows how the output pressure profile matches the setpoint dial value (our simulated analog input). The accuracy of the tracked pressure will depend on the PID settings as well as pressure and flow capability of the pump.

---

**TAKE NOTE**

Since every system is different it will be necessary to adjust the proportional and integral coefficients (i.e. the values in the P and I boxes) to achieve the best response to setpoint changes.

---

To make the pump follow a pressure profile defined by the analog input voltage you will need to change the Setpoint to 'Analog Input' in the GUI and provide a control voltage that corresponds to the target pressure signal.

Finally, where an external pressure sensor is used to monitor pressure, this can be used as the "Input" to the PID loop (appropriately scaled using the "System Inputs" panel), with the "Setpoint" set to either "Manual" or "Dial".

## 10.7 Multi pump control

The Disc Pump Control application can control multiple pumps at once. Each pump can either be individually connected to the host computer (a Smart Pump Module with USB-serial cable, Development or Evaluation kit) or multiple Smart Pump Modules can be connected through one Development kit (see Section 9.1.4 for how to configure multiple Smart Pump Modules).

To add controls for additional pumps, click on the plus button on the top left. This will generate a new pump control tab. Tabs can also be closed with the X button.



Figure 60 Adding and removing additional pump control tabs.

Pump control tabs work similarly to browser tabs in Google Chrome or Microsoft Edge. They can be dragged out to create new windows, dragged in to bring in a new window back as a tab or be rearranged. This functionality is supported for both the pump control tabs and the plot tabs. Note that when a plot tab is created it is tied to the last active pump control tab (the last one that was clicked on) and therefore will display the output of that pump.

Note that controlling multiple pumps may cause performance issues on some computers. The typical performance issues are low framerate on the application or the graph appearing blocky. One way of mitigating the low framerate is to hide some of the plot tabs, reduce the number of variables that are plotted or reduce the Plot time axis as described in Section 10.3. The graph appearing blocky can happen with Smart Pump Modules connected over I2C, if the Smart Pump Module is using an old Firmware version (before v6.16). If this is the case, contact your local Lee representative for further information on how to upgrade the Firmware version. This plotting artifact can also happen if too many Smart Pump Modules are connected over I2C.

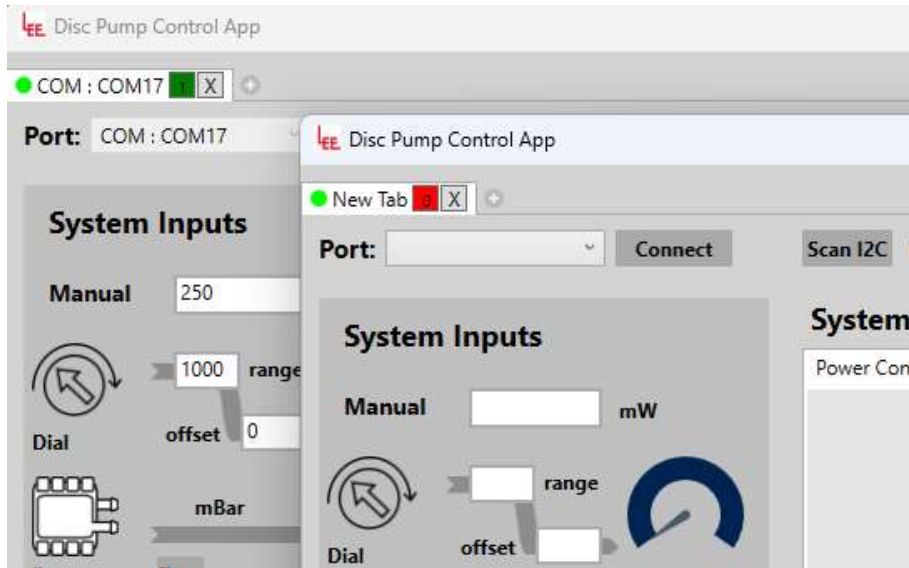

Figure 61 Dragging out tabs in separate windows.

When a pump control tab is in a standalone window as shown in Figure 62, the plot area is left empty and a plot can be created either through the “+” button (similar to how it is created when first starting the application) or by dragging in a plot window. Similarly, for plot tabs in standalone windows there is a “+” button on the top to generate a pump control tab or one can be dragged in.



Figure 62 Multiple pump control tabs and multiple plot tabs. Pump control tab with a plot tab (left), a standalone pump control tab (middle) and a standalone plot tab (right).

To help identify which tab corresponds to which pump, the colour of each tab can be changed with the slider on the left. This causes the tab circle in the application and the board status LED on the device to change colour accordingly. Note that the LED and screen colour may differ slightly due to variations in the monitor and LED colour accuracy. Note that LED colour change on the Smart Pump Module is supported

in firmware versions 6.16 and above. Additionally, tabs can be renamed by right-clicking on the tab name or the colour indicator.

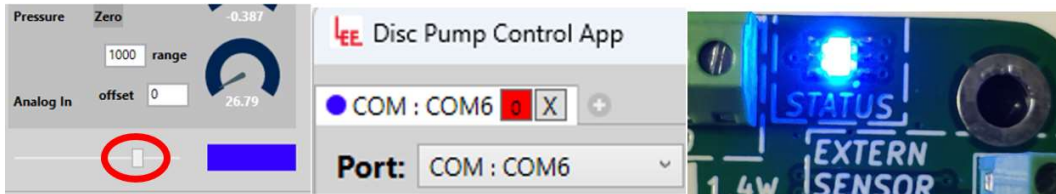

Figure 63 Colour changing of tabs and status LED.

Controlling multiple pumps at once works in the same way as controlling a single pump. There are a few additional controls to make this task simpler.

- The STOP ALL button turns all connected pumps off and resets all valves to their default states.
- Each pump can be turned on/off without opening the relevant tab by clicking the little red/green square on the tab header. 1 (green) indicates the pump is on and 0 (red) indicates the pump is off.

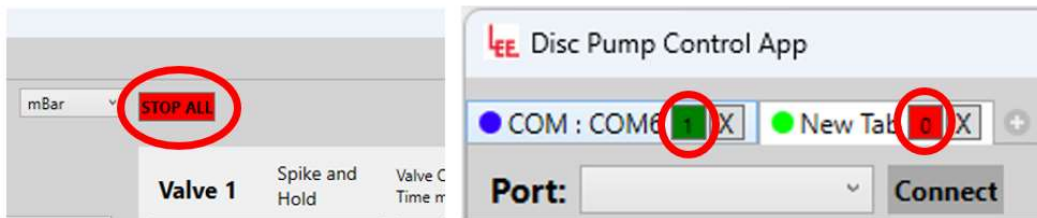

Figure 64 Stop all button (left) and pump on/off control from tab title (right).

## 10.8 Logging

Data can be logged to a CSV file for offline analysis.

- In the “Logging” panel, click the “Select Folder“ button as shown in Figure 65. This will prompt a folder selection where the data will be generated.
- Once the folder is selected the interface will indicate the new location as shown in Figure 66. When the logging is started the app will automatically create a .CSV log file in the target folder.
- Click the Start Logging button to initiate the logging. The interface shows the name of the created file and the number of logged points going up as shown in Figure 66. Once sufficient data is obtained click the Stop Logging data.
- Data from multiple pumps connected to the app can be logged simultaneously. The ALL button will do the same as pressing the normal logging button on all tabs simultaneously (i.e. if it says stop logging the all button will stop all tabs logging). Start all will not restart any tabs already logging but Stop will stop logging all, not just the tabs started by start all.

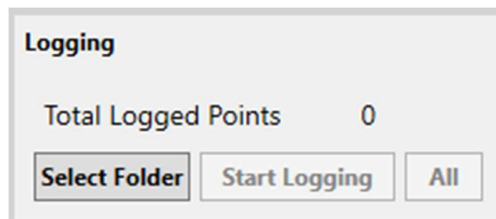

Figure 65 Data logging interface.

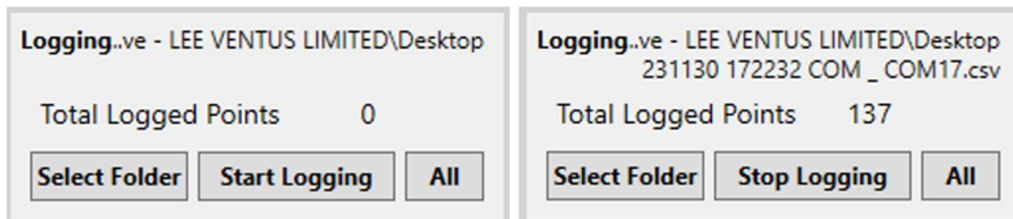

Figure 66 Data logging interface when target folder is selected (left). Data logging interface while data logging is active (right).

### 10.9 Board settings menu

All writable settings of the Smart Pump Module and the General Purpose Drive PCB can be accessed via the “Settings” button on the top right of the window. This brings out a separate window which lists the register ID, register name and has a field for editing the value. Consult the ‘TG003: Communications Guide’ for full information on registers functionality and appropriate values.

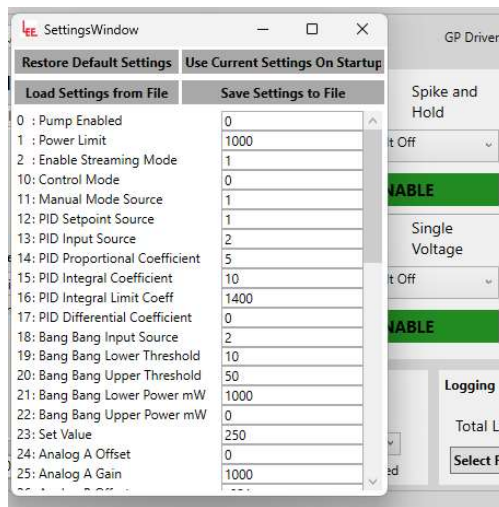

Figure 67 Settings menu.

The board settings can be saved to be used at start-up (otherwise the settings are lost upon rebooting the board). To do this use click on the “Use Current Settings On Startup”. This is required for setting some registers as they only take effect after rebooting the board.

The board settings can also be saved and loaded from a file which can be useful for transferring settings between multiple boards or when troubleshooting the system with the Lee customer support. This functionality can be accessed through the “Save / Load Settings from File buttons”.



Finally, the default board settings can be restored to factory defaults through the Restore Default Settings button. Note that the settings will be erased on rebooting unless they are saved to be used at start-up.

## 11 ACCESSORIES

The following accessories are available. Contact your local Lee Company representative for more information or visit The Lee Company's website.

### 11.1 Disc Pumps

The Lee Company's range of piezoelectric micropumps is enabling innovation across sectors from medical and life sciences to environmental and industrial. The micropumps deliver unrivalled pressure and flow, silent operation, rapid response time, precision, and ultra-smooth flow – all in a tiny package, promoting wearability, portability, and simplicity.

| Product line | Summary  | Image  |
|--------------|--|--|
| BL Series    | Entry-level pumps striking a balance between performance and cost. |   |
| XP Series    | Highest performance and widest temperature range of -25°C to 55°C. |  |
| LT Series    | Long life models offering 17,000+ hours of continuous operation    |  |
| HP Series    | High pressure model.   |  |
| US Series    | Slimline models with integrated filter                             |  |

## 11.2 Mains power supply (UACX500950E)

The mains power supply allows the Development Kit to power more than one Disc Pump and valves. The power supply provides 5A of current at 5V and is equipped with a range of mains adapters for use in different countries. The power supply has suitable transient recovery time to cope with sudden changes in load (e.g. when valves switch or when the pump ramps-up).

More detailed product specifications and manuals can be found on the original manufacturer's website (check the manufacturer part number on the product label) or on request from The Lee Company.



Figure 68 Mains power supply.

## 11.3 Smart Pump Module

The Smart Pump Module (SPM) can be used to enhance our piezoelectric disc pumps with drive electronics and pressure sensing. This standalone pump module offers precision control that is not possible with conventional pumping technology. It is compatible with any of our disc pumps, including the BL, XP, LT, or HP Series pumps. The module's closed-loop feedback from the pressure sensor allows for exceptional pressure and vacuum regulation, benefiting from the unique features of the disc pumps.



Figure 69 Smart Pump Module equipped with an XP series pump.

## 11.4 The Lee Company Valves

### 11.4.1 HDI valves

The High Density Interface (HDI) control solenoid valve is a compact and lightweight design making it the ideal solution for applications where a large number of valves must be designed into small spaces. Available in 2-port and 3-port configurations, HDI Solenoid Valves enable designers to meet critical system-level performance requirements without making compromises. Whether you're looking for low power consumption, low leakage or quiet operation, the HDI valve is your solution that provides unmatched reliability.

The Development Kit is compatible with 12V HDI rated for DC operation (Spike and hold or Latching models not supported). The ports on the ported HDI variant compatible with the tubing included in the Development Kit, while other variants can be adapted to the tubing with Lee manifolds. The Any Port Inlet HDI variant allows bidirectional flow through the valve which allows greater design flexibility.



Figure 70 HDI valve range. The ported variant is shown on the top left.

### 11.4.2 VHS valves

This small dispensing valve combines inkjet printing technology with inert materials to achieve precision droplets in the nanoliter to milliliter range. With an ultra-fast response time (as fast as 250  $\mu$ s), it is ideal for accurate fluid regulation and dispensing repeatable droplets with minimal satellites. The valve's small size enables mounting in tight spaces, even in arrays directly above a well plate. It is offered with integrated precision orifices, nozzles, screens, or with our MINSTAC® connectors to vary the outlet nozzle and connect tubing. Each valve is customizable and 100% tested to ensure performance.

The Development Kit is compatible with VHS valves rated for 12V spike voltage and 1.6V hold voltage.



Figure 71 VHS valve range.

## 11.5 Replacement parts

### 11.5.1 Development motherboard (UEKA0300100A)

A spare or replacement motherboard can be purchased. Note that the motherboard is unable to drive a pump in isolation, a General Purpose Drive PCB or a Smart Pump Module is also required.

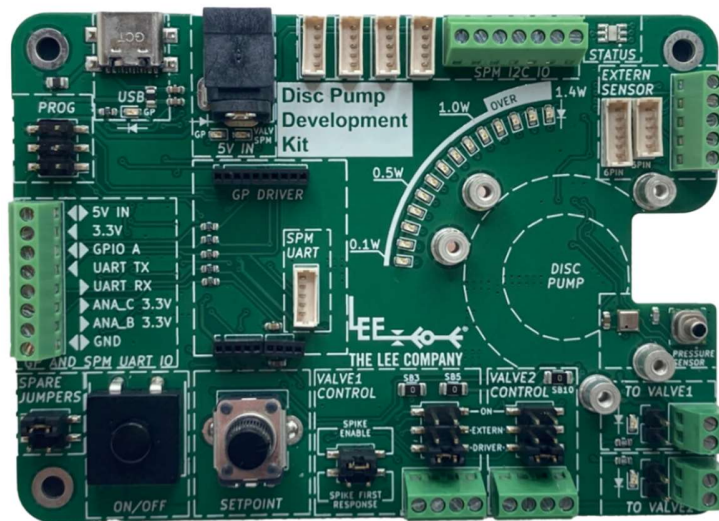

Figure 72: Development motherboard

### 11.5.2 General Purpose drive PCB (UEKA0300000A)

A spare or replacement General Purpose drive PCB can be purchased. The General Purpose drive PCB slots into the Development motherboard and provides open loop and closed loop of the Piezoelectric Disc Pump.



Figure 73 General Purpose drive PCB

### 11.5.3 Pneumatic accessories

Some of the pneumatic accessories included in the Development Kit (such as orifices, V and Y couplers and filters) can be purchased separately as spares or replacements. Contact your local Lee sales representative for more information.

## 11.6 Other off-the-shelf components

Some of the components included in the Development Kit are not sold separately. Ordering information for these components is provided below.

### 11.6.1 Smart Pump Module cable and Liquid flow sensors cables

The Smart Pump Module and Sensirion LG16 liquid flow sensors require a Molex Picoblade 5pin female-female cable. The Sensirion LSF3S liquid flow sensors requires the 6pin variant of the same cable. Off the shelf cables can be found on online electronics retailers such as Mouser or RS Components.

### 11.6.2 Pneumatic couplers and tubing

The pneumatic couplers included in the Development Kit (e.g. T-connector) are 3/32" barbed connectors and they are available from many online retailers. The pneumatic tube supplied with the kit is 2mm ID, 4mm OD silicone tube, available from many online retailers.

## 12 SUPPORT AND ADDITIONAL GUIDES

The disc pump product pages of The Lee Company website provides technical information, FAQs, troubleshooting and documentation for download, including a range of application notes, including:

- ‘TG001: Disc Pump Drive Guide’: a guide on how to drive Disc Pump effectively with your own electronics.
- ‘TG003: PCB Serial Communications Guide’: a serial communications guide, for taking control of the Development kit, General Purpose driver PCB or the Smart Pump Module with your own hardware.
- ‘GitHub Code Snippet Library’: providing example code for using the Disc Pump products with external microcontrollers (like Arduino) and scripting languages (like Python). <https://github.com/The-Lee-Company>
- ‘TG005: Disc Pump Wear Characteristics’
- ‘AN007: Microfluidics Driver Application Note: Piezoelectric Disc Pumps’: prototyping with the Disc Pump Evaluation Kit and Sensirion SLF3x Series Flow Sensor
- ‘AN002: Microfluidics Application Note: Piezoelectric Disc Pumps’
- ‘AN049: Pipetting Application Note: Piezoelectric Disc Pumps’
- ‘AN069: Time-metered dosing: Piezoelectric Disc Pumps’: showcasing a system that uses the Lee VHS valve to dispense small droplets.
- ‘Disc Pump Reference Design Package’: a pack of reference designs for the firmware and drive PCB.

For additional technical support, please contact your local Lee Sales Engineer.

## 13 REVISION HISTORY

| Revision | Date       | Details   |
|----------|------------|---|
| V01      | 06/03/2024 | Initial release. The functionality described in this user manual is available with the release of the:<br>General Purpose Driver Board firmware version 15.11<br>Smart Pump Module firmware version 6.16<br>Disc Pump Control App version 2.0 |